

CHAPTER 12

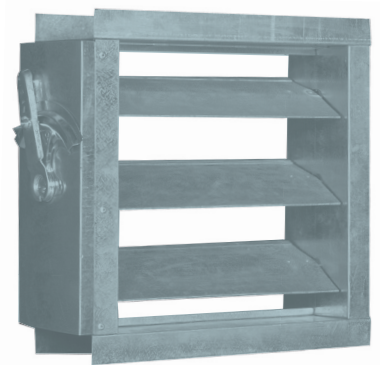

VOLUME CONTROL DAMPERS



CONTENTS

Flanged Volume Control Dampers – Model VCD-F1.

Flanged Volume Control Dampers – Model VCD-F2.

Flanged Volume Control Dampers – Model VCD-F3.

Slip and Clip Volume Control Dampers – Model VCD-S1.

Slip and Clip Volume Control Dampers – Model VCD-S2.

Slip and Clip Volume Control Dampers – Model VCD-S3.

Round Volume Control Dampers – Model VCD-R.

Ordering Data.

VOLUME CONTROL DAMPERS



Model	VCD - F1
Shape	Square or Rectangular
Connection	Flanged Type
Blades Section	Double Skin Aerofoil
Blades Construction	Extruded Aluminium
Blades Operation	Manual (Parallal or Opposed)



Features & Characteristics

- VCD – F1 single or multi – leaf dampers have been specifically designed for use in ventilation systems for volume, flow and pressure control in square and rectangular ducts and air handling units.
- Dampers are ruggedly built, with a casing of robust assembly formed from channel frame for flanged connection to ductwork.
- The blades design provides lower pressure drop in the open position for smooth air motion with reduced turbulence.
- Available in wide variety of standard duct sizes ranging from 100 x 100 mm up to 1200 x 1200 mm in 50 mm increments (other non – standard sizes are available on request).
- Any size combination with a height up to 150 mm is manufactured in single blade unit. Other sizes are manufactured in multi blades unit.

Construction Details

Frame : Galvanized steel , 16 or 18 gauge depending on damper size. Formed channel for flanged connection.

Flange Width : 30 mm (standard).

Blades : Extruded Aluminium, double skin with aerofoil section.

Finish :

Frame : Mill Galvanized.

Blades : Mill Aluminium.

Axle : Blades rotating around its centre by means of zinc plated steel connecting axle (Spindle).

Bearings : Blades are fixed with the frame by means of plastic bushes.

Linkage : Zinc plated steel side mounted linkage concealed inside the frame.

Blades Seal : As an option, blades rubber gasket seal at one edge is available on request to seal blade to blade joint for low air leakage operation.

Hand Locking Quadrant : Unless otherwise required, all dampers are equipped with external galvanized steel hand quadrant as standard to :

- Adjust damper opening position.
- Indicate damper opening position.
- Lock the blades at the desired position.

Also, dampers are available with extended steel shaft suitable for electrical actuator assembly.

Minimum Size : 100 x 100 mm.

Maximum Size : 1200 x 1200 mm as a single section. Multiple section assembly is unlimited where each section operates independently.

Model VCD - F1

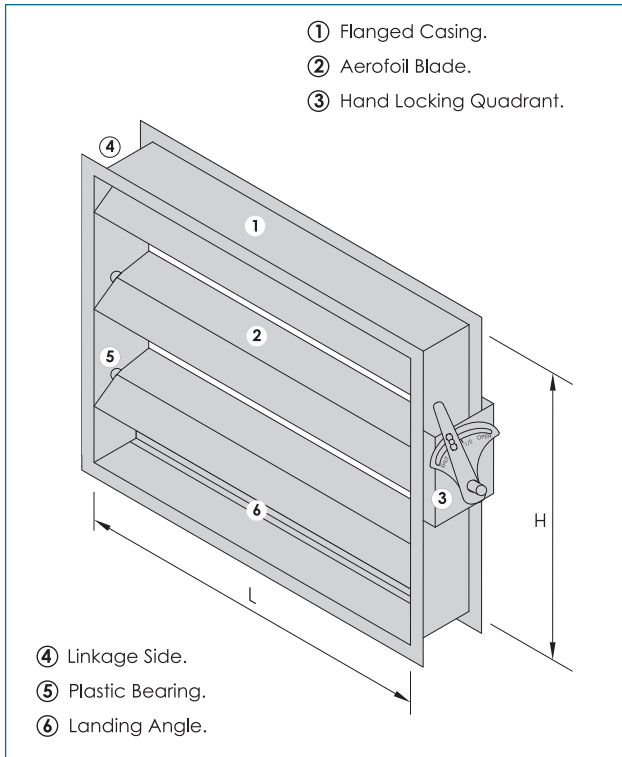

Blades and Linkage Operation

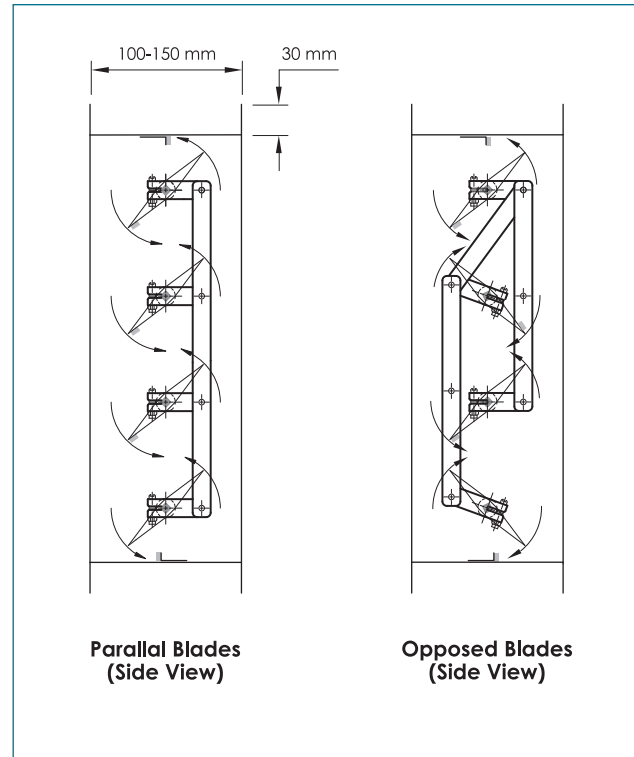

Engineering & Performance Data

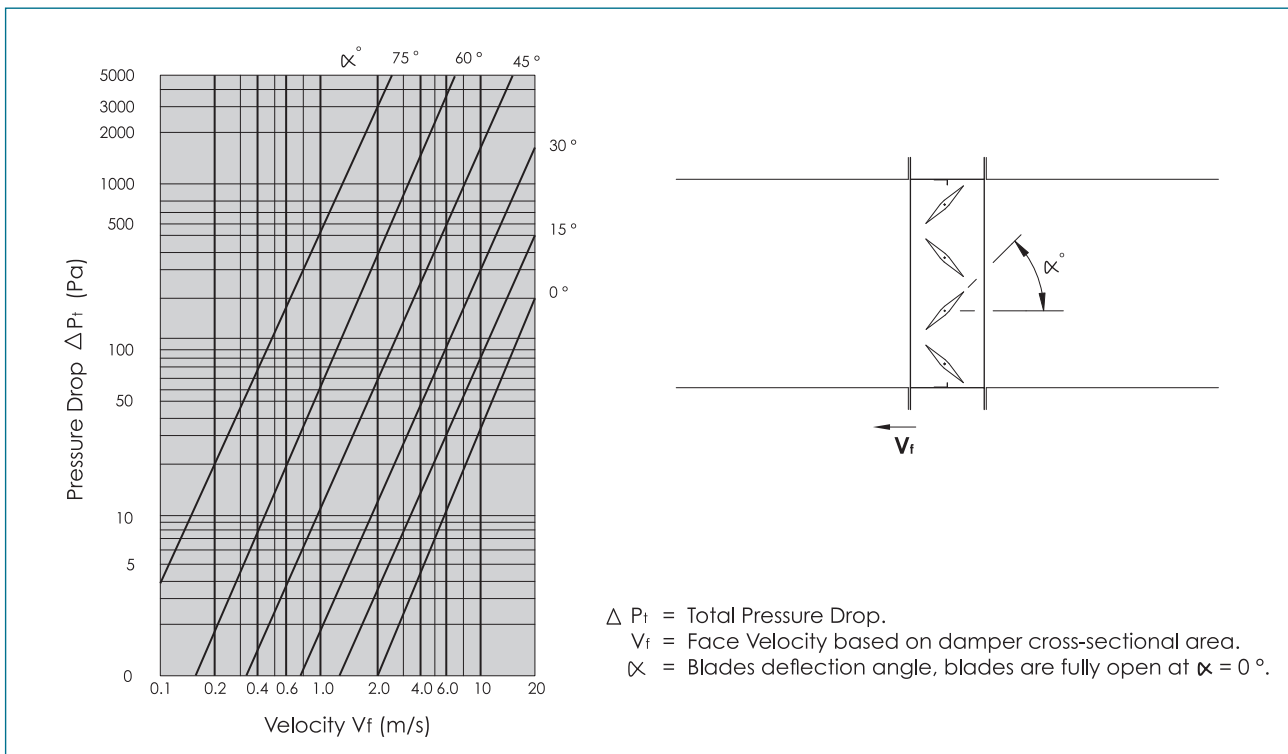

Model	VCD - F2
Shape	Square or Rectangular
Connection	Flanged Type
Blades Section	Double Skin Aerofoil
Blades Construction	Galvanized Steel
Blades Operation	Manual (Parallal or Opposed)

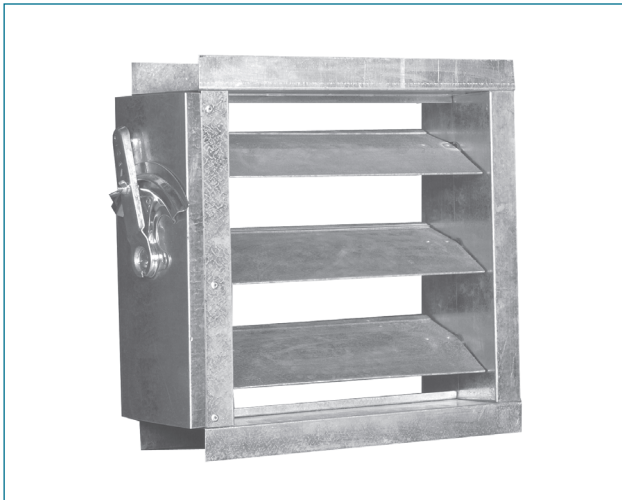

Features & Characteristics

- VCD – F2 single or multi – leaf dampers have been specifically designed for use in ventilation systems for volume, flow and pressure control in square and rectangular ducts and air handling units.
- Dampers are ruggedly built, with a casing of robust assembly formed from channel frame for flanged connection to ductwork.
- The blades design provides lower pressure drop in the open position for smooth air motion with reduced turbulence.
- Available in wide variety of standard duct sizes ranging from 100 x 100 mm up to 1200 x 1200 mm in 50 mm increments (other non – standard sizes are available on request).
- Any size combination with a height up to 250 mm is manufactured in single blade unit. Other sizes are manufactured in multi blades unit.

Construction Details

Frame : Galvanized steel , 16 or 18 gauge depending on damper size. Formed channel for flanged connection.

Flange Width : 30 mm (standard).

Blades : Galvanized steel sheet, double skin with aerofoil section.

Finish :

Frame : Mill Galvanized.

Blades : Mill Aluminium.

Axle : Blades rotating around its centre by means of zinc plated steel connecting axle (Spindle).

Bearings : Blades are fixed with the frame by means of plastic bushes.

Linkage : Zinc plated steel side mounted linkage concealed inside the frame.

Blades Seal : As an option, blades rubber gasket seal at one edge is available on request to seal blade to blade joint for low air leakage operation.

Hand Locking Quadrant : Unless otherwise required, all dampers are equipped with external galvanized steel hand quadrant as standard to :

- Adjust damper opening position.
- Indicate damper opening position.
- Lock the blades at the desired position.

Also, dampers are available with extended steel shaft suitable for electrical actuator assembly.

Minimum Size : 100 x 100 mm.

Maximum Size : 1200 x 1200 mm as a single section. Multiple section assembly is unlimited where each section operates independently.

Model VCD - F2

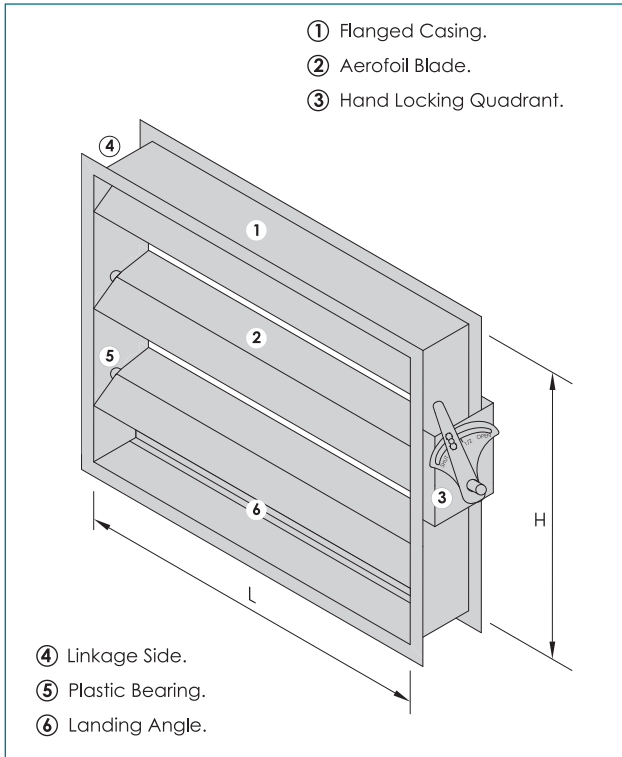

Blades and Linkage Operation

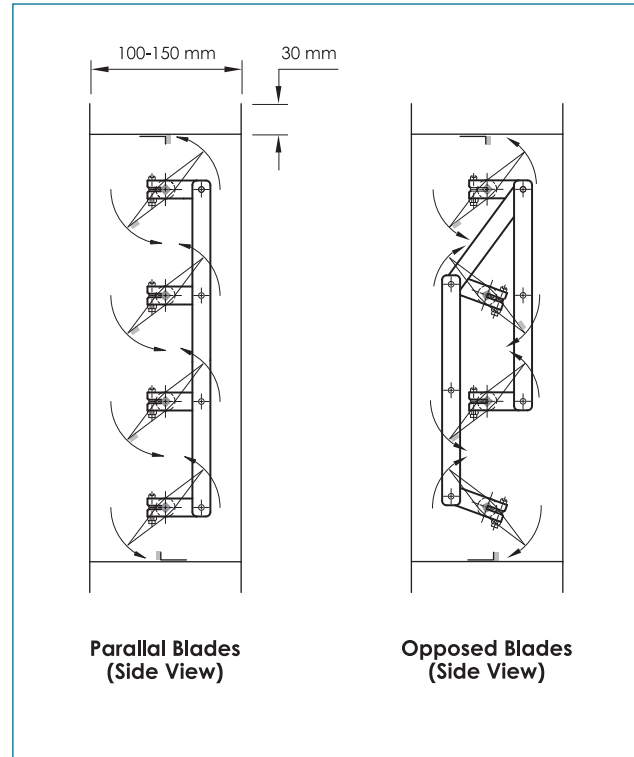

Engineering & Performance Data

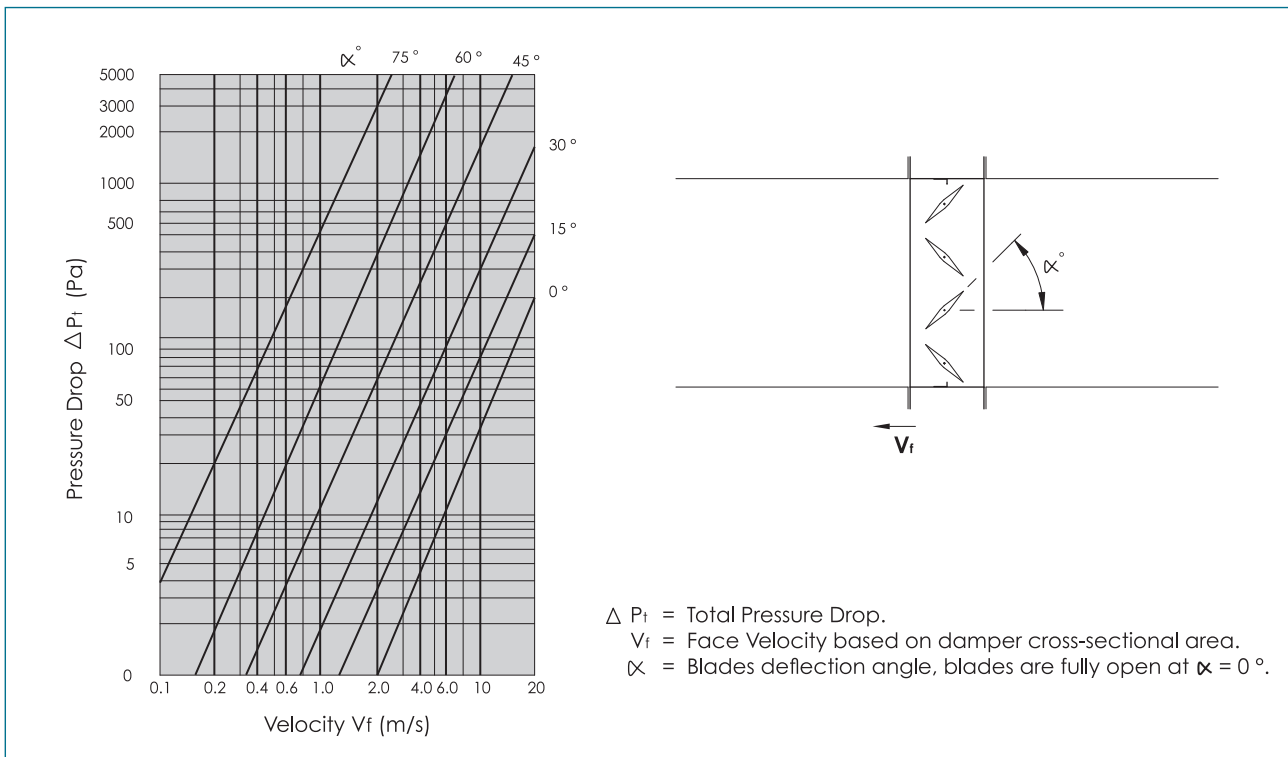

Model	VCD - F3
Shape	Square or Rectangular
Connection	Flanged Type
Blades Section	3V - Single Skin Blade
Blades Construction	Galvanized Steel
Blades Operation	Manual (Parallal or Opposed)



Features & Characteristics

- VCD – F3 single or multi – leaf dampers have been specifically designed for use in ventilation systems for volume, flow and pressure control in square and rectangular ducts and air handling units.
- Dampers are ruggedly built, with a casing of robust assembly formed from channel frame for flanged connection to ductwork.
- The blades design provides lower pressure drop in the open position for smooth air motion with reduced turbulence.
- Available in wide variety of standard duct sizes ranging from 100 x 100 mm up to 1200 x 1200 mm in 50 mm increments (other non – standard sizes are available on request).
- Any size combination with a height up to 250 mm is manufactured in single blade unit. Other sizes are manufactured in multi blades unit.

Construction Details

Fame : Galvanized steel , 16 or 18 gauge depending on damper size. Formed channel for flanged connection.

Flange Width : 30 mm (standard).

Blades : Galvanized steel sheet, " 3V " formed, single skin blades.

Finish :

Frame : Mill Galvanized.

Blades : Mill Galvanized.

Axle : Blades rotating around its centre by means of zinc plated steel stud.

Bearings : Blades are fixed with the frame by means of plastic bushes.

Linkage : Zinc plated steel side mounted linkage concealed inside the frame.

Blades Seal : As an option, blades rubber gasket seal at one edge is available on request to seal blade to blade joint for low air leakage operation.

Hand Locking Quadrant : Unless otherwise required, all dampers are equipped with external galvanized steel hand quadrant as standard to :

- Adjust damper opening position.
 - Indicate damper opening position.
 - Lock the blades at the desired position.
- Also, dampers are available with extended steel shaft suitable for electrical actuator assembly.

Minimum Size : 100 x 100 mm.

Maximum Size : 1200 x 1200 mm as a single section. Multiple section assembly is unlimited where each section operates independently.

Model VCD - F3

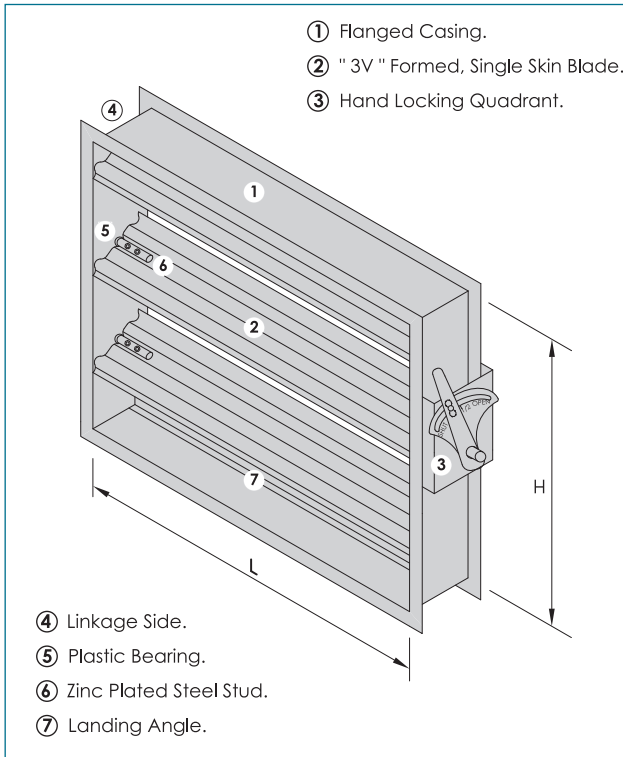

Blades and Linkage Operation

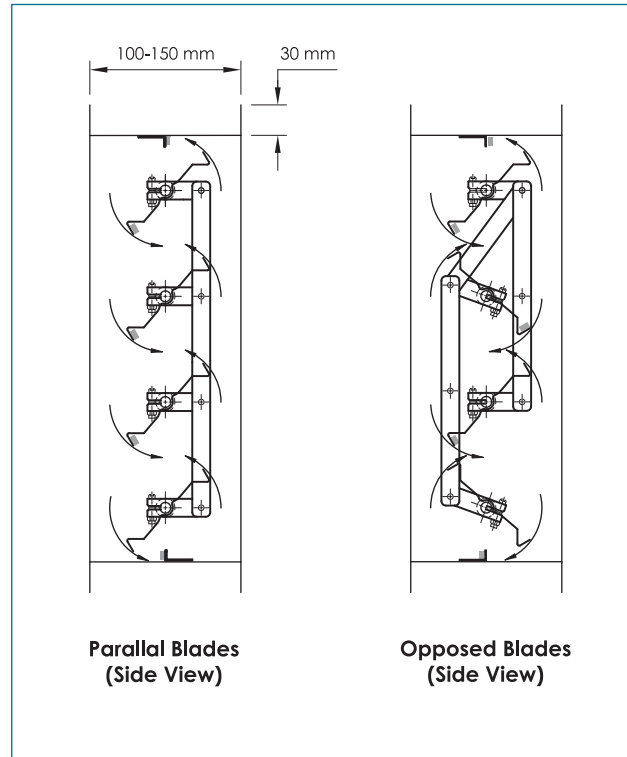

Engineering & Performance Data

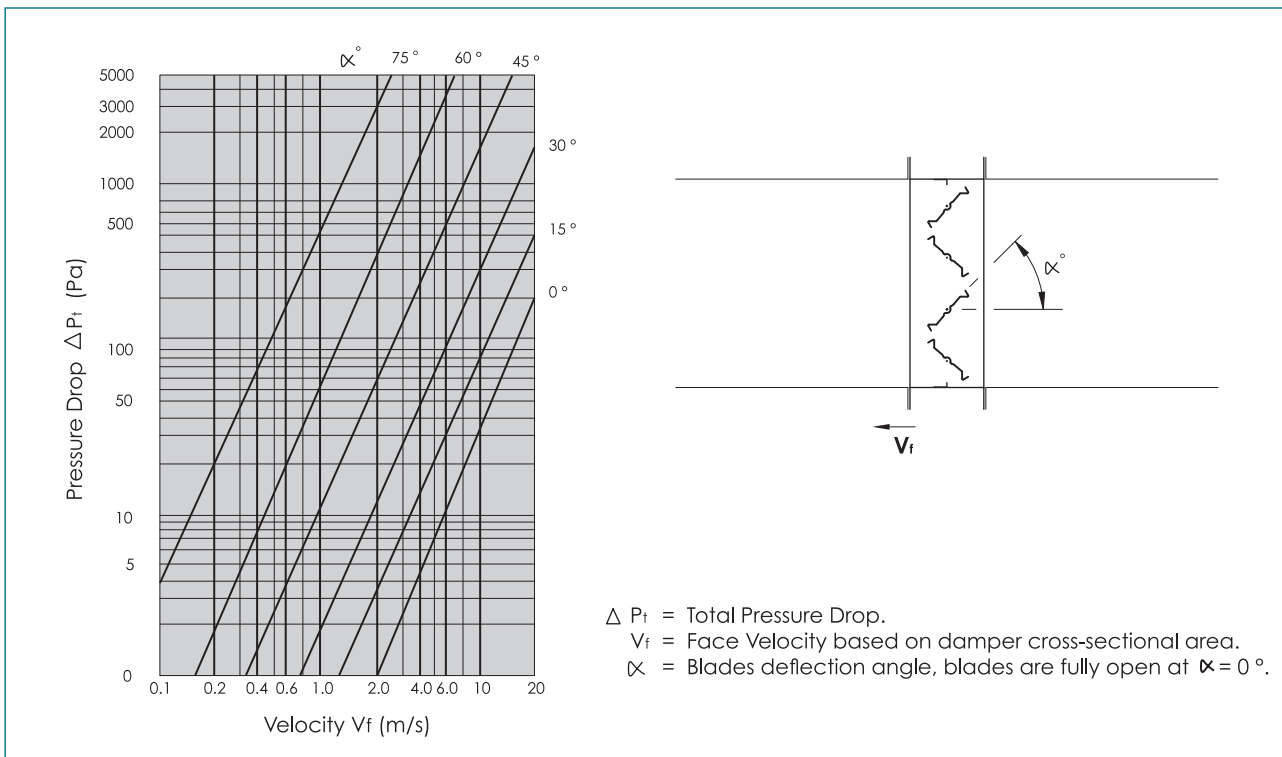

Model	VCD - S1
Shape	Square or Rectangular
Connection	Slip & Clip Type
Blades Section	Double Skin Aerofoil
Blades Construction	Extruded Aluminium
Blades Operation	Manual (Parallal or Opposed)



Features & Characteristics

- VCD – S1 single or multi – leaf dampers have been specifically designed for use in ventilation systems for volume, flow and pressure control in square and rectangular ducts and air handling units.
- Dampers are ruggedly built, with a casing of robust assembly formed from channel frame for flanged connection to ductwork.
- The blades design provides lower pressure drop in the open position for smooth air motion with reduced turbulence.
- Available in wide variety of standard duct sizes ranging from 100 x 100 mm up to 1200 x 1200 mm in 50 mm increments (other non – standard sizes are available on request).
- Any size combination with a height up to 150 mm is manufactured in single blade unit. Other sizes are manufactured in multi blades unit.

Construction Details

Frame : Galvanized steel , 16 or 18 gauge depending on damper size. Formed for Slip and Clip connection to ductwork.

Blades : Extruded Aluminium, double skin with aerofoil section.

Finish :

Frame : Mill Galvanized.

Blades : Mill Aluminium.

Axle : Blades rotating around its centre by means of zinc plated steel connecting axle (Spindle).

Bearings : Blades are fixed with the frame by means of plastic bushes.

Linkage : Zinc plated steel side mounted linkage concealed outside the frame.

Blades Seal : As an option, blades rubber gasket seal at one edge is available on request to seal blade to blade joint for low air leakage operation.

Hand Locking Quadrant : Unless otherwise required, all dampers are equipped with external galvanized steel hand quadrant as standard to :

- Adjust damper opening position.
- Indicate damper opening position.
- Lock the blades at the desired position.

Also, dampers are available with extended steel shaft suitable for electrical actuator assembly.

Minimum Size : 100 x 100 mm.

Maximum Size : 1200 x 1200 mm as a single section. Multiple section assembly is unlimited where each section operates independently.

Model VCD - S1

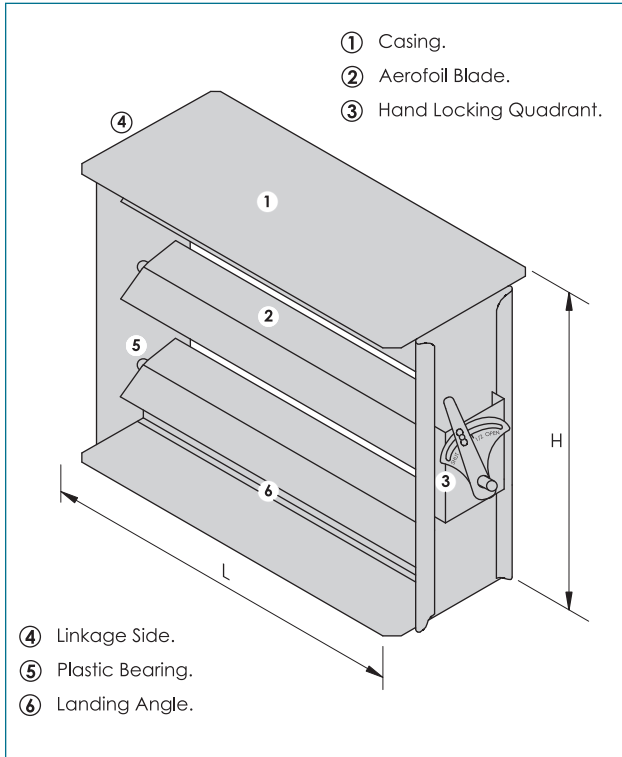

Blades and Linkage Operation

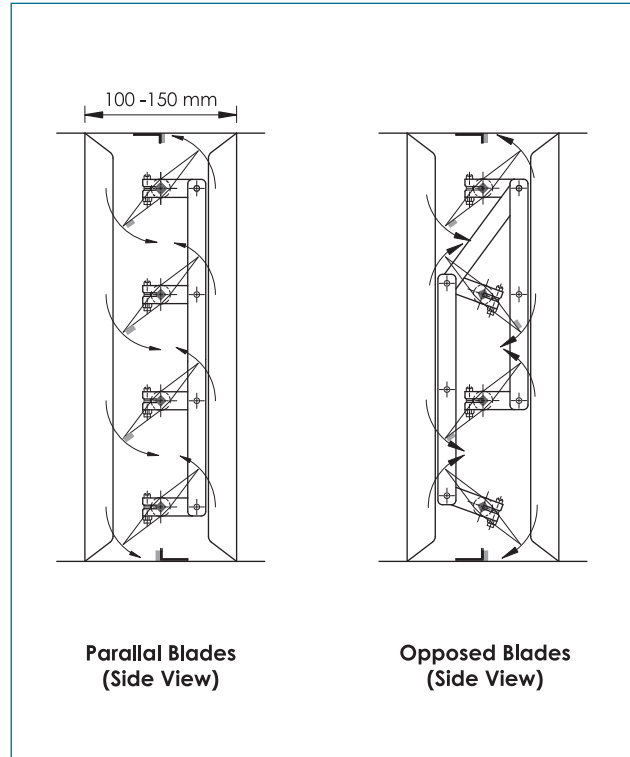

Engineering & Performance Data

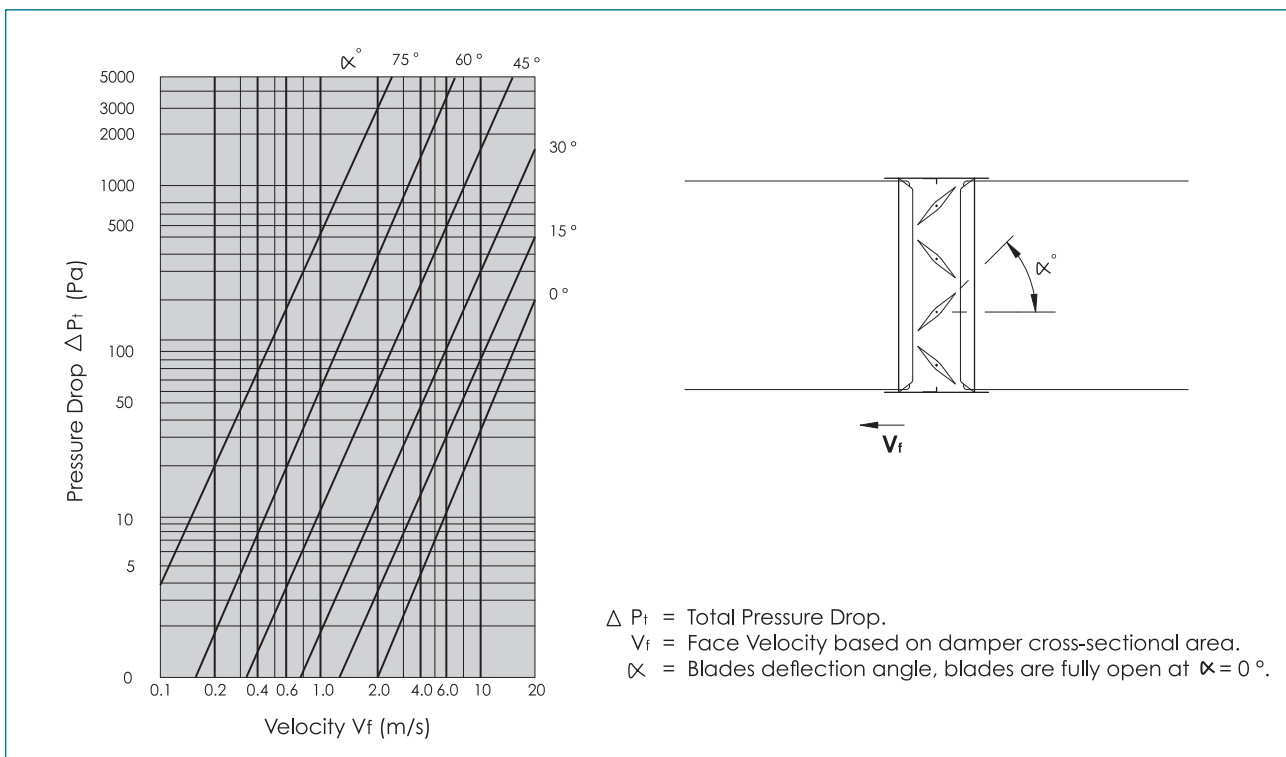

Model	VCD - S2
Shape	Square or Rectangular
Connection	Slip & Clip Type
Blades Section	Double Skin Aerofoil
Blades Construction	Galvanized Steel
Blades Operation	Manual (Parallal or Opposed)



Features & Characteristics

- VCD – S2 single or multi – leaf dampers have been specifically designed for use in ventilation systems for volume, flow and pressure control in square and rectangular ducts and air handling units.
- Dampers are ruggedly built, with a casing of robust assembly formed from channel frame for flanged connection to ductwork.
- The blades design provides lower pressure drop in the open position for smooth air motion with reduced turbulence.
- Available in wide variety of standard duct sizes ranging from 100 x 100 mm up to 1200 x 1200 mm in 50 mm increments (other non – standard sizes are available on request).
- Any size combination with a height up to 250 mm is manufactured in single blade unit. Other sizes are manufactured in multi blades unit.

Construction Details

Frame : Galvanized steel , 16 or 18 gauge depending on damper size. Formed for Slip and Clip connection to ductwork.

Blades : Galvanized steel sheet, double skin with aerofoil section.

Finish :

Frame : Mill Galvanized.

Blades : Mill Galvanized.

Axle : Blades rotating around its centre by means of zinc plated steel connecting axle (Spindle).

Bearings : Blades are fixed with the frame by means of plastic bushes.

Linkage : Zinc plated steel side mounted linkage concealed outside the frame.

Blades Seal : As an option, blades rubber gasket seal at one edge is available on request to seal blade to blade joint for low air leakage operation.

Hand Locking Quadrant : Unless otherwise required, all dampers are equipped with external galvanized steel hand quadrant as standard to :

- Adjust damper opening position.
- Indicate damper opening position.
- Lock the blades at the desired position.

Also, dampers are available with extended steel shaft suitable for electrical actuator assembly.

Minimum Size : 100 x 100 mm.

Maximum Size : 1200 x 1200 mm as a single section. Multiple section assembly is unlimited where each section operates independently.

Model VCD - S2

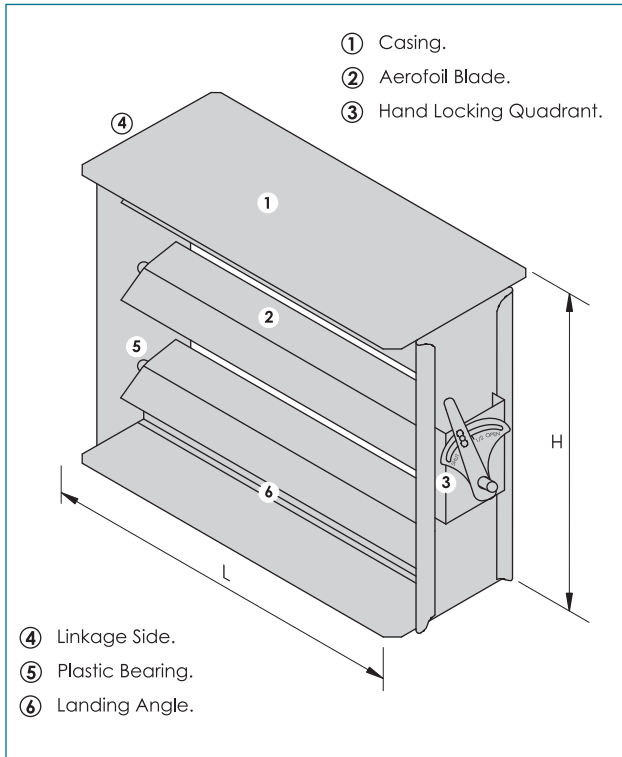

Blades and Linkage Operation

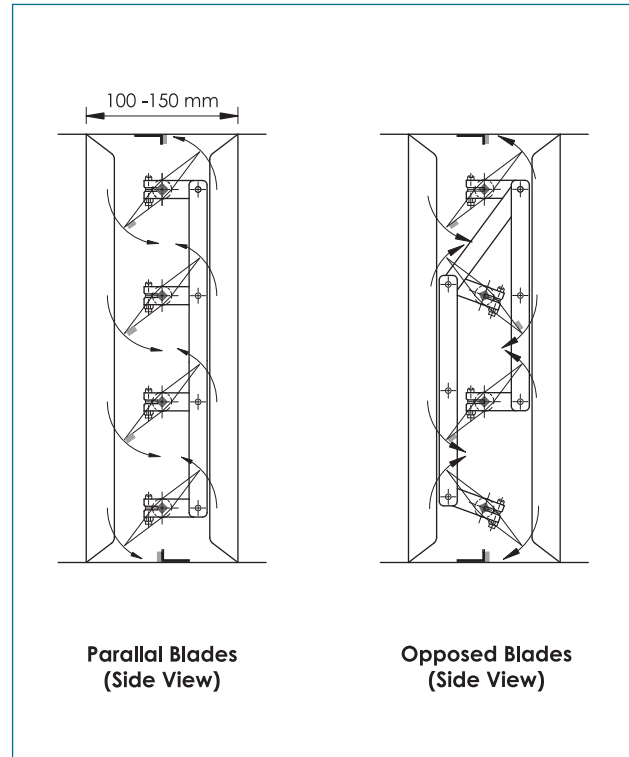

Engineering & Performance Data

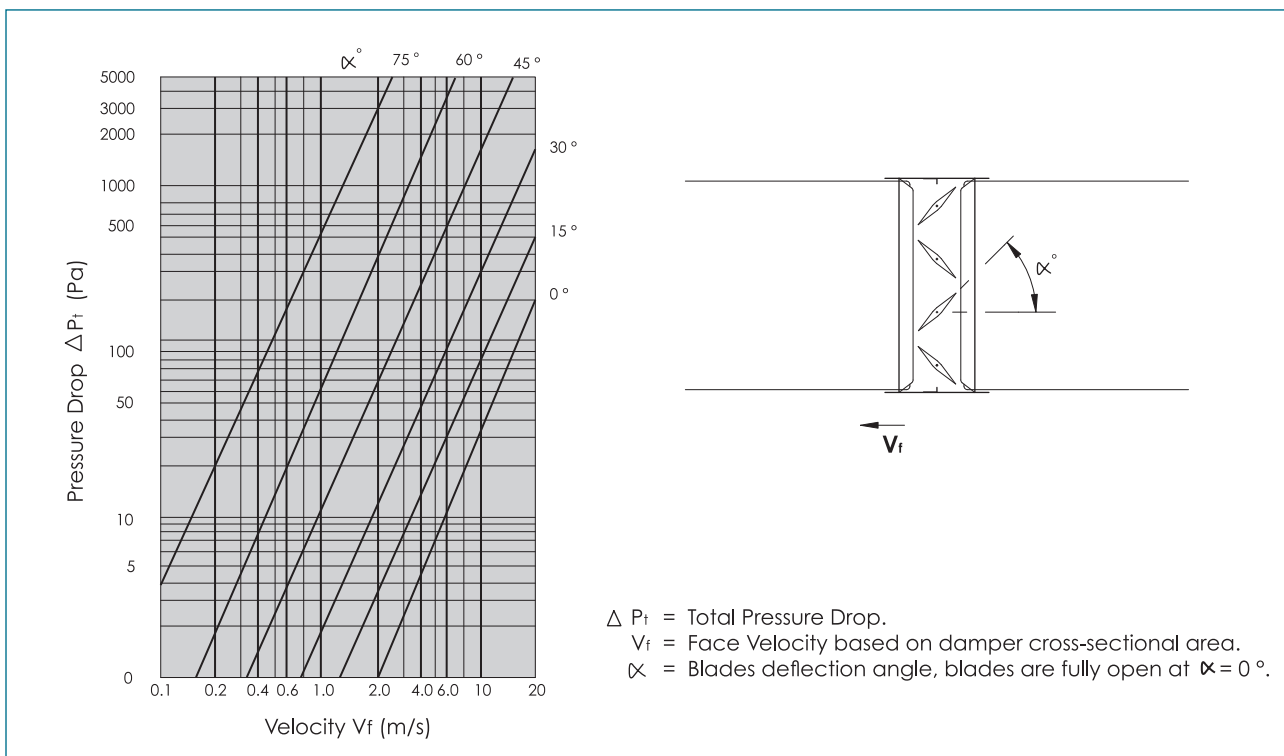

Model	VCD - S3
Shape	Square or Rectangular
Connection	Slip & Clip Type
Blades Section	3V - Single Skin Blade
Blades Construction	Galvanized Steel
Blades Operation	Manual (Parallal or Opposed)



Features & Characteristics

- VCD – S3 single or multi – leaf dampers have been specifically designed for use in ventilation systems for volume, flow and pressure control in square and rectangular ducts and air handling units.
- Dampers are ruggedly built, with a casing of robust assembly formed from channel frame for flanged connection to ductwork.
- The blades design provides lower pressure drop in the open position for smooth air motion with reduced turbulence.
- Available in wide variety of standard duct sizes ranging from 100 x 100 mm up to 1200 x 1200 mm in 50 mm increments (other non – standard sizes are available on request).
- Any size combination with a height up to 250 mm is manufactured in single blade unit. Other sizes are manufactured in multi blades unit.

Construction Details

Frame : Galvanized steel , 16 or 18 gauge depending on damper size. Formed for Slip and Clip connection to ductwork.

Blades : Galvanized steel sheet, " 3V " formed, single skin blades.

Finish :

Frame : Mill Galvanized.

Blades : Mill Galvanized.

Axle : Blades rotating around its axis by means of zinc plated steel stud.

Bearings : Blades are fixed with the frame by means of plastic bushes.

Linkage : Zinc plated steel side mounted linkage concealed in the frame.

Blades Seal : As an option, blades rubber gasket seal at one edge is available on request to seal blade to blade joint for low air leakage operation.

Hand Locking Quadrant : all dampers are equipped with external galvanized steel hand quadrant to :

- Adjust damper opening position.
- Indicate damper opening position.
- Lock the blades at the desired position.

Also, dampers are available with extended steel shaft suitable for electrical actuator assembly.

Minimum Size : 100 x 100 mm.

Maximum Size : 1200 x 1200 mm as a single section. Multiple section assembly is unlimited where each section operates independently.

Model VCD - S3

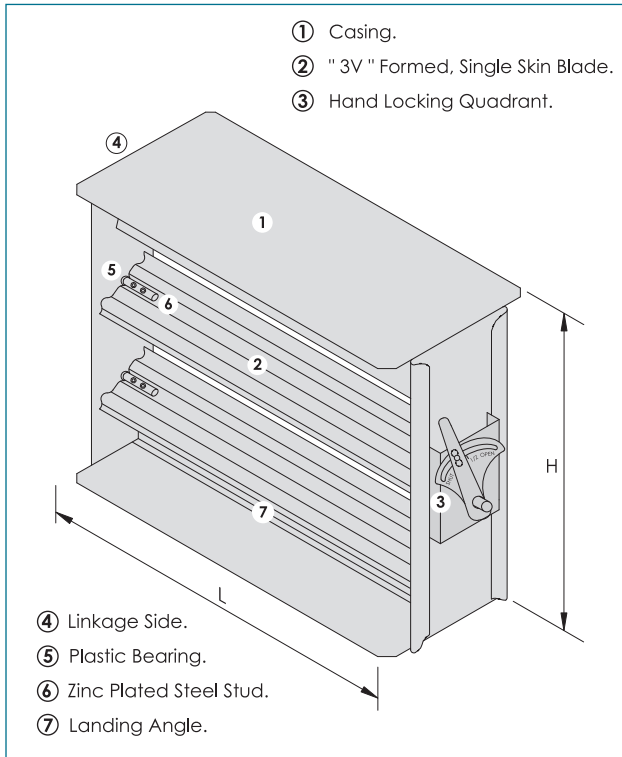

Blades and Linkage Operation

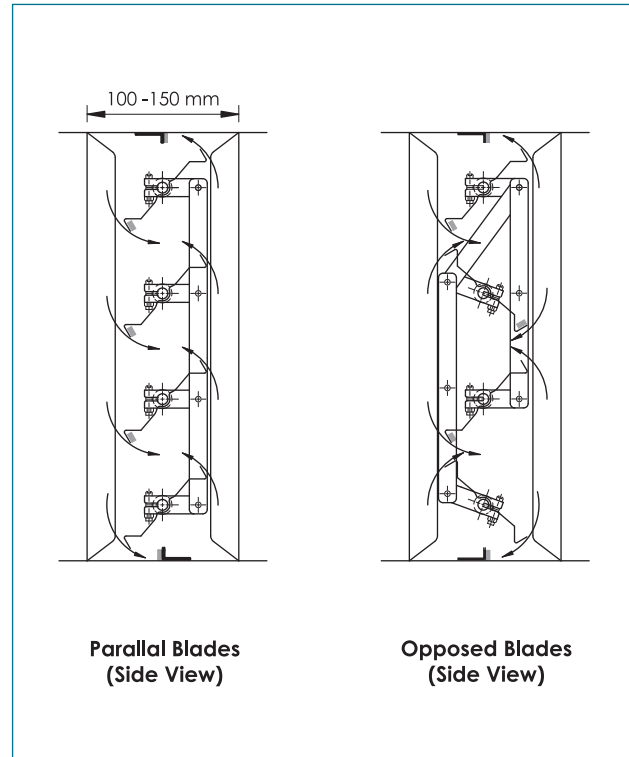

Engineering & Performance Data

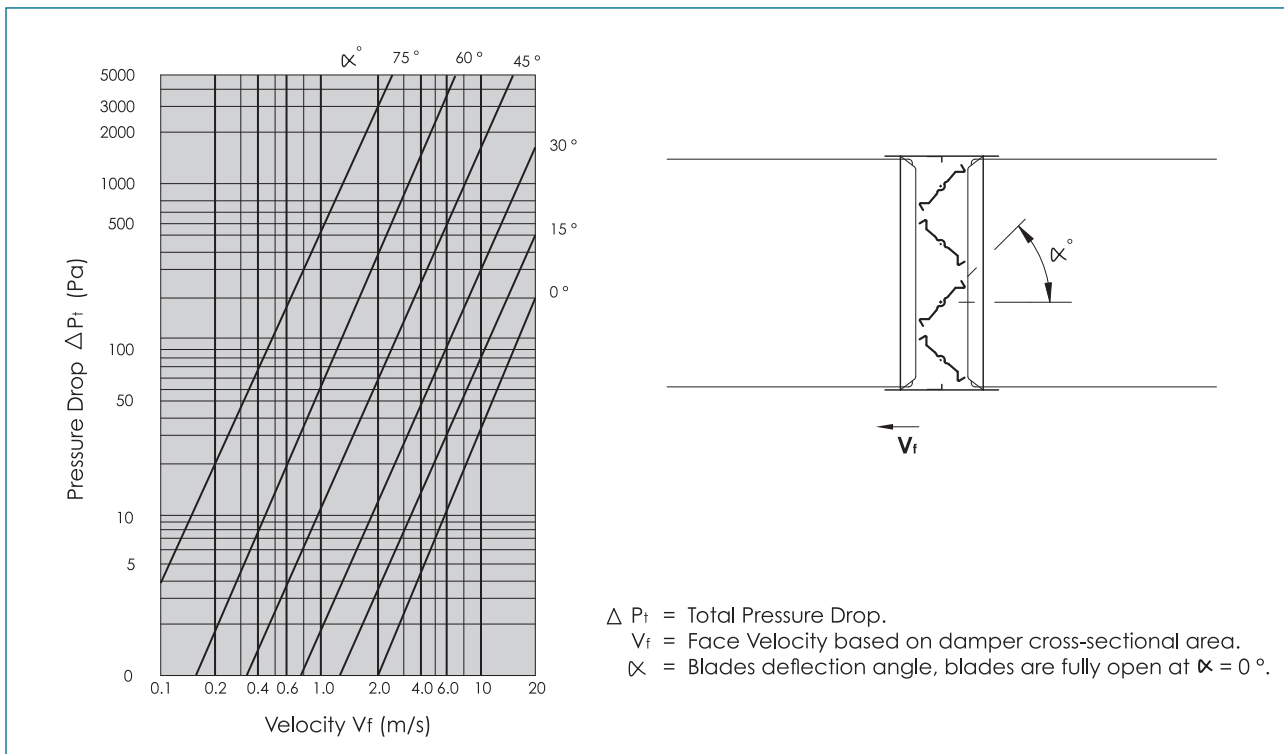

Model	VCD - R
Shape	Round (Circular)
Connection	Open Ends w/o Flanges
Type of Ends	Grooved or Straight
Blade Section	Single Skin Blade
Blade Construction	Galvanized Steel

Features & Characteristics

- VCD – R round type volume control dampers have been specifically designed for the use in circular duct installations and at the connections between flexible ducts and the inlets of supply air plenums to regulate air flow and control pressure.
- Also these dampers can be used as Shut – Off dampers when sealing against air flow is required.
- Available with open :
 - Grooved Ends or,
 - Straight Ends.
- Available in wide variety of standard duct sizes ranging from 100 mm Ø up to 600 mm Ø in 50 mm increments.

Construction Details

Casing : Galvanized steel , 18 or 20 gauge depending on damper size. Circular formed for circular duct connections.

Ends Type : Open Grooved Ends or, Open Straight Ends.

Blade : Galvanized steel sheet, circular formed, single skin blade.

Finish :
 Casing : Mill Galvanized.
 Blade : Mill Galvanized.

Axle : Blade rotating around its centre by means of zinc plated steel connecting axle (Spindle).

Bearings : Blade are fixed with the frame by means of plastic bushes.

Hand Locking Quadrant : Unless otherwise required, all dampers are equipped with external galvanized steel hand quadrant as standard to :

- Adjust damper opening position.
- Indicate damper opening position.
- Lock the blades at the desired position.

Also, dampers are available with extended steel shaft suitable for electrical actuator assembly.

Minimum Size : 100 mm Ø.
Maximum Size : 600 mm Ø.



Model VCD - R

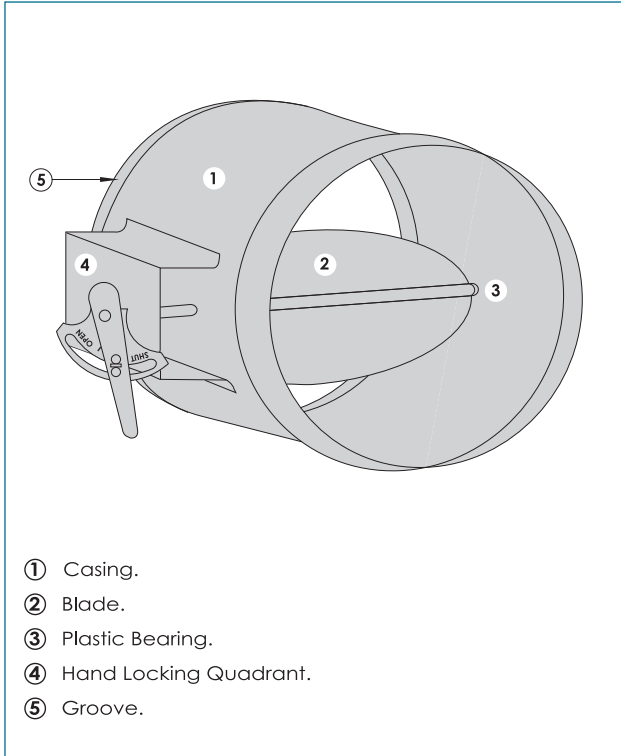

Type of Ends and Connections

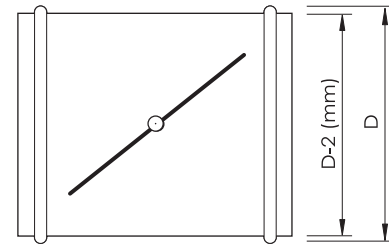

Open Grooved Ends

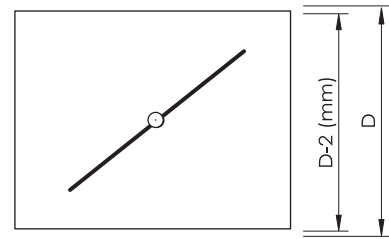

Open Straight Ends

D : Duct diameter Size in (mm).

Engineering & Performance Data

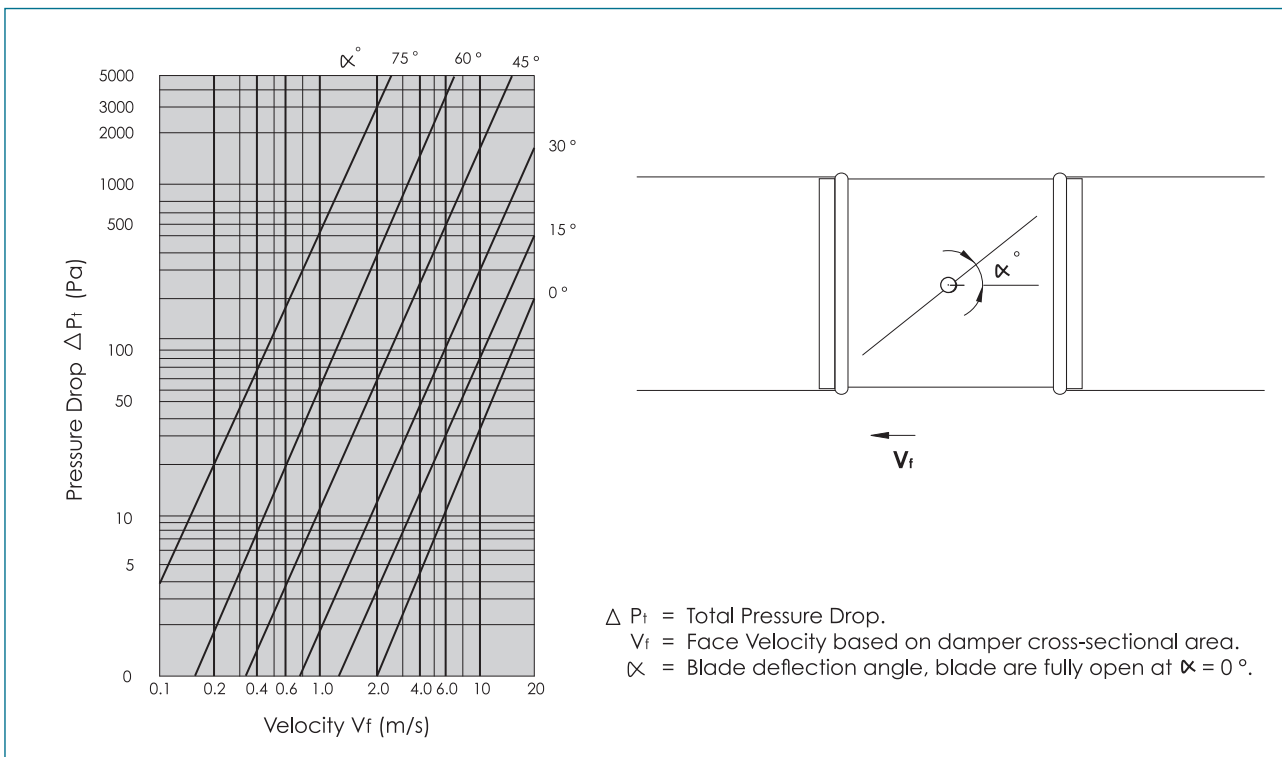

Ordering Data

● Ordering Specifications :

Specify :

- 1 . VCD – Model (VCD-F1,F2,F3,S1,.....etc).
- 2 . Duct Size.
- 3 . Quantity.
- 4 . Blades operation, Parallel or Opposed type (this specification is not applicable for the Model VCD-R).
- 5 . Type of Ends, Grooved or Straight (only mention for the Model VCD-R).
- 6 . Blades Seal Rubber Gasket (Optional Accessories).

Example 1 :

1	2	3	4	5	6
VCD-F1	12" x 8" 300 x 200 (mm)	22	Parallel	—	—

Example 2 :

1	2	3	4	5	6
VCD-S1	24" x 16" 600 x 400 (mm)	5	Opposed	—	With Blades Seal

Example 3 :

1	2	3	4	5	6
VCD-R	10" Ø 250 mm Ø	30	—	Grooved Ends	—

A series of horizontal dotted lines spanning the width of the page, providing a template for handwritten notes or technical specifications.

A series of horizontal dotted lines spanning the width of the page, providing a template for handwritten notes or technical specifications.