

# CHAPTER 4

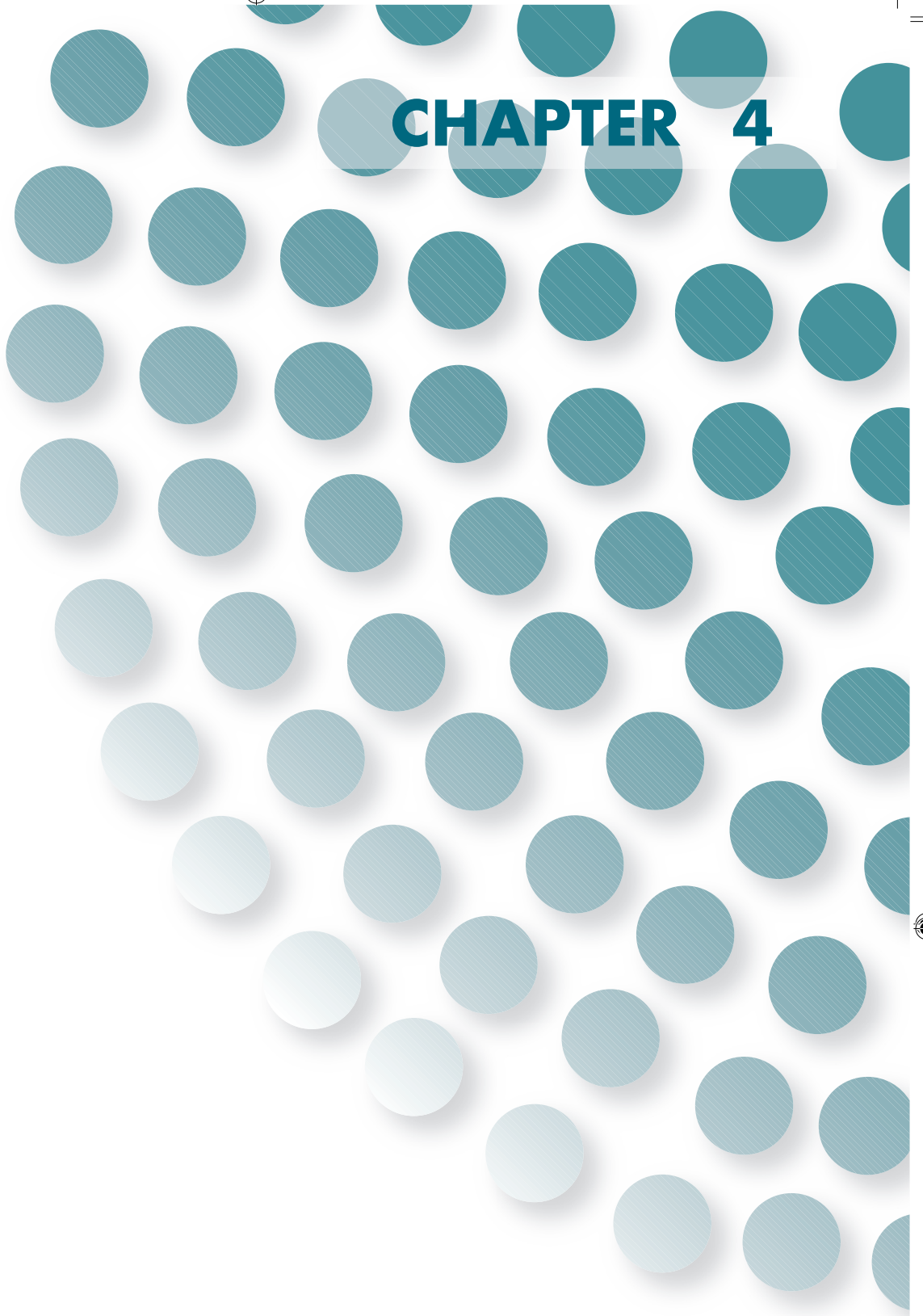

## LINEAR BAR GRILLES AND REGISTERS



**CONTENTS**

**Introduction, Features & Characteristics, Models Available.**

**Core Styles (Deflection and Spacing), Operating Range.**

**Multi Sections , Mitered Corners.**

**End Cap / Flange Arrangements, Linear Bar Grilles / Registers in Curved Shape.**

**Models, Linear Bar Registers / Grilles with Vertical Rear Blades.**

**Models, Linear Bar Registers / Grilles w/o Rear Blades.**

**Linear Bar Grilles / Registers Accessories.**

**Profiles used in Linear Bar Grilles / Registers, Available Fixing Mounting.**

**Effective Area Values for Linear Bar Grilles and Registers.**

**Selected Effective Area Values.**

**General Selection Diagram.**

**Using General Selection Diagram, Illustrative Examples.**

**Ordering Data.**

**LINEAR BAR GRILLES AND REGISTERS**





# LINEAR BAR GRILLES AND REGISTERS



The fixed Bar Grilles / Registers are used satisfactorily in locations where flow direction is not critical or can be predetermined. The Linear Grilles / Registers with fixed horizontal bars satisfy the architectural requirements of large areas where continuous input along the walls is requested for wall mounted installations, windowsill and covering furniture for fan coils.

### Features & Characteristics :

- Construction : Frame & Face bars are made of high quality Extruded Aluminium Profiles of 6063 Alloy.
- Frame Flange width : 30 mm.
- Face Bars (core style) : available in two different bar deflections, the standard one is the 15 ° - 2 way deflection and the optional one is the 15 ° - 1 way deflection (see table No. LG - 02).
- Bar Spacing : Spacing of the adjacent fixed bar blades are set at 12 mm as standard. Also available in 9 and 6 mm spacing as an option (see table No. LG - 02).
- Available with vertical Aluminium aerofoil rear blades fixed to the frame by means of nylon bushes. These blades can be adjusted manually and individually in the vertical plane to achieve the optimum throw deflection and air distribution.
- The frame is assembled by punching it's four corners by means of G. I. Angles which together create a very robust construction.
- For Continuous runs, units are supplied in sections and can be designed to incorporate additional features such as active / dummy sections and mitered corners (see table No. LG - 03, 04, 05 & 06 ).
- To maintain perfect and unbroken appearance for continuous runs, alignment joining strips are provided in proper lengths and quantities with no extra cost.
- Available in wide variety of standard heights ranging from 50 mm neck size up to 300 mm in 50 mm increments (other none standard sizes are available on request).
- Linear Bar Grilles combined with Opposed Blade Damper are called Linear Bar Registers.
- Mullion Pipes across the fixed bar blades provide additional strength and rigid construction. These Pipes are placed at a distance of 300 mm maximum from each other.
- Accessories : see page No. LG - 07.
- Available Fixing Mounting : see page No. LG - 08.
- Surface Finishes : see page No. LG - 13.

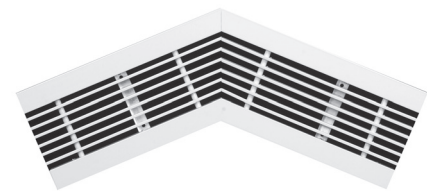
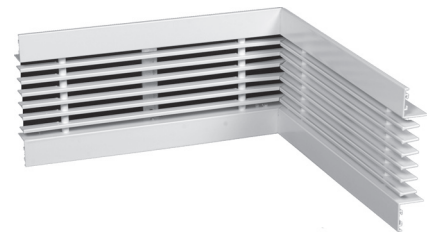
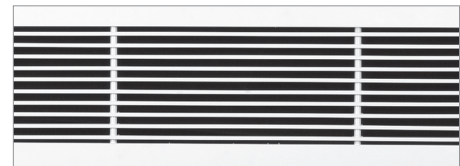
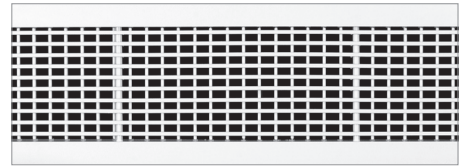
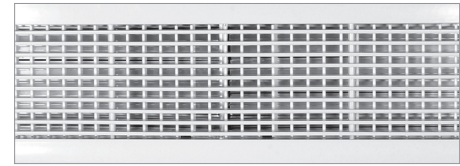

### Models Available :

TABLE LG - 01

Linear Bar Grilles / Registers Model	Fixed Bar Blades w/o Vertical Rear Blades	Fixed Bar Blades with Vertical Rear Blades	Opposed Blade Damper
SLR		●	●
SLG		●	
RLR	●		●
RLG	●		

● Available.



## Core Styles (Deflection and Spacing)

TABLE LG - 02

15° - Two Way Deflection		
<p><b>Standard</b></p> <p>Spacing = 12 mm</p>	<p><b>Optional</b></p> <p>Spacing = 9 mm</p>	<p><b>Optional</b></p> <p>Spacing = 6 mm</p>
15° - One Way Deflection		
<p><b>Optional</b></p> <p>Spacing = 12 mm</p>	<p><b>Optional</b></p> <p>Spacing = 9 mm</p>	<p><b>Optional</b></p> <p>Spacing = 6 mm</p>

• All Dimensions are in mm and subject to ± 0.5 mm tolerance.

TABLE LG - 03

OPERATING RANGE & QUICK SELECTION TABLE FOR LINEAR BAR GRILLES / REGISTERS									
WITH VERTICAL REAR BLADES					W/O REAR BLADES				
Standard Heights		Length mm	CFM Range		Standard Heights		Length mm	CFM Range	
Inch	mm		Inch	mm	Inch	mm		Inch	mm
4"	100	1000	350	800	4"	100	1000	500	1100
6"	150		550	1250	6"	150		725	1650
8"	200		725	1700	8"	200		950	2100
10"	250		850	2000	10"	250		1250	2500
12"	300		1080	2300	12"	300		1450	3400
4"	100	1500	550	1250	4"	100	1500	700	1600
6"	150		800	1850	6"	150		1075	2350
8"	200		1080	2300	8"	200		1425	3150
10"	250		1300	2600	10"	250		1875	3750
12"	300		1600	3700	12"	300		2175	5100
4"	100	2000	750	1600	4"	100	2000	1000	2200
6"	150		1100	2500	6"	150		1450	3300
8"	200		1450	3400	8"	200		1900	4200
10"	250		1700	4000	10"	250		2500	5000
12"	300		2160	4600	12"	300		2900	6800

• CFM Values are based on Noise Level ranging from 15 - 35 (dB).

BCI reserves the right to make changes without prior notice.

TABLE LG - 04

LINEAR BAR GRILLE / REGISTER HEIGHT		NO. OF SECTIONS PER RUNNING UNIT		
mm	Inch	ONE SECTION	TWO SECTIONS	MULTI SECTIONS
50	2 "	≤ 4.0	> 4.0	> 6.0
100	4 "	≤ 4.0	> 4.0	> 6.0
150	6 "	≤ 4.0	> 4.0	> 6.0
200	8 "	≤ 4.0	> 4.0	> 6.0
250	10"	≤ 3.5	> 3.5	> 6.0
300	12"	≤ 3.5	> 3.5	> 6.0

● Above arrangements are approximate and subject to change according to order / site conditions.

## MITERED CORNERS

TABLE LG - 05

TABLE LG - 06

### Wall Mounted Corners

**1) Inside 90° Corner Standard**

**2) Outside 90° Corner Standard**

**3) Variable Angle Inside/Outside Corner Optional**

### Ceiling Mounted Corners

**4) 90° Corner Optional**

**5) Variable Angle Corner Optional**

● Corners are always supplied in 300 x 300 mm adjacent sides as standard unless otherwise specified or required.

## End Cap / Flange Arrangements

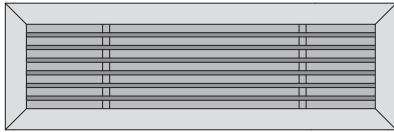

End Cap at Both Sides

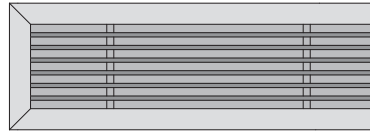

End Cap at One Side

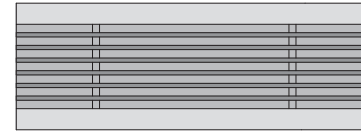

Open Ends

## Linear Bar Grilles / Registers in Curved Shape

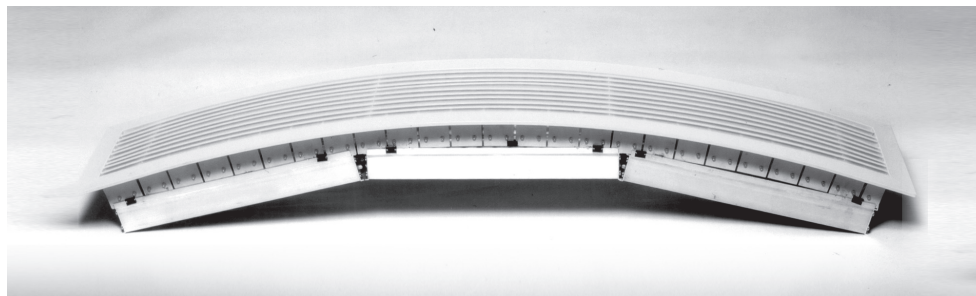
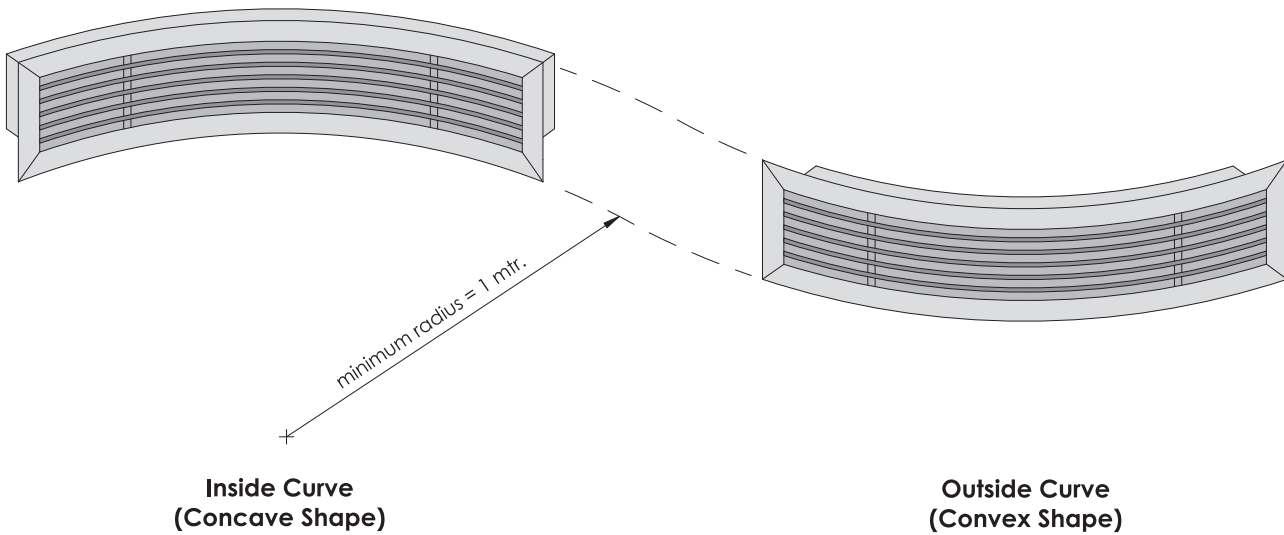

- Curves can be fabricated in minimum curvature radius = 1 mtr.
- Curve applications can be fabricated also for linears with rear blades.
- Curve applications are not possible for ceiling installations.



## Linear Bar Registers with Vertical Rear Blades Construction and Dimensional Details

### Model SLR DD

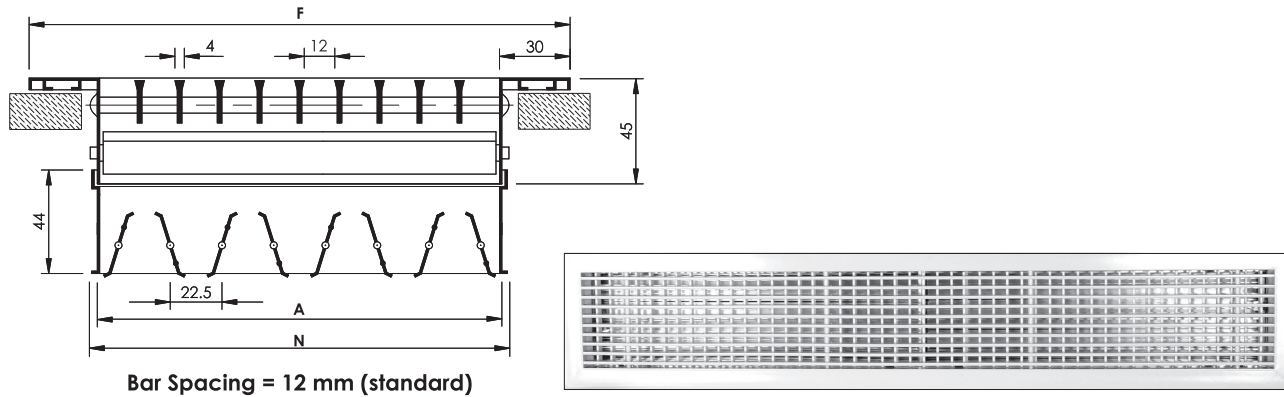

- **SLR** : is Supply Air Linear Bar Register, fixed horizontal front bar blades, adjustable vertical rear blades, c/w Opposed Blade Damper.
- Registers called Supply Air Linear Bar Register and coded as **SLR** are always equipped with Opposed Blade Damper (provided as standard).

## Linear Bar Grilles with Vertical Rear Blades Construction and Dimensional Details

### Model SLG DD

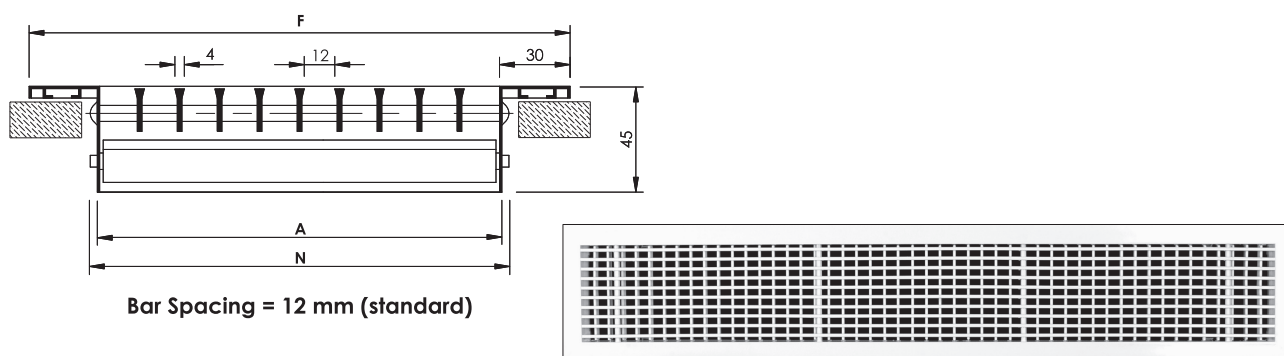

- **SLG** : is Supply Air Linear Bar Grille, fixed horizontal front bar blades, adjustable vertical rear blades w/o Opposed Blade Damper.
- Grilles called Supply Air Linear Bar Grille and coded as **SLG** are usually supplied w/o Opposed Blade Damper.

**N** : Nominal/Listed Size = Length (L) x Height (H)  
**A** : Actual Size = (L-10) x (H-10)  
**F** : Face Size = (L+50) x (H+50)

- Linear Bar Grilles / Registers furnished approximately 10 mm less than the Nominal/Listed Size.
- All dimensions are in mm and subject to  $\pm 1$  mm tolerance.

## Linear Bar Registers Without Rear Blades Construction and Dimensional Details

### Model RLR SD

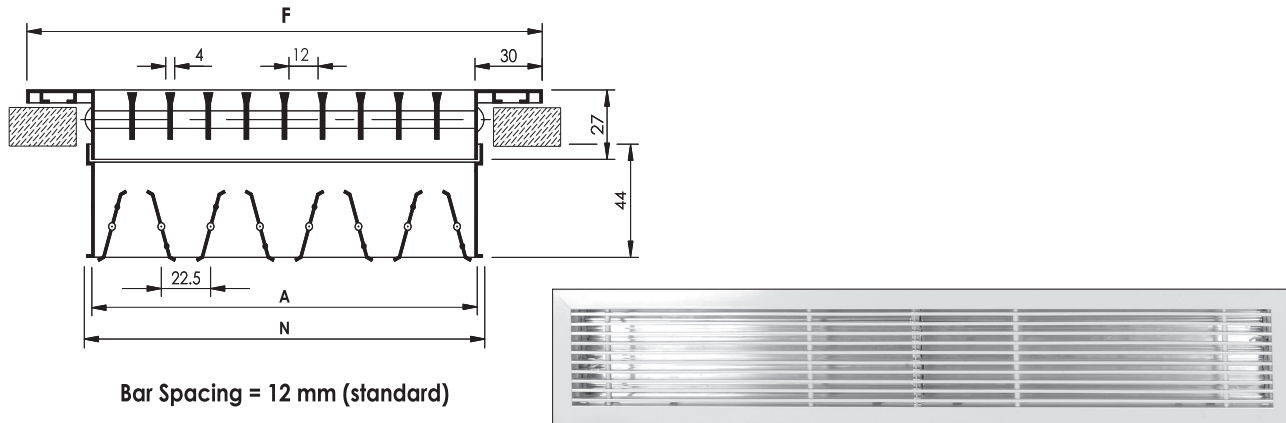

- **RLR** : is Return Air Linear Bar Register, fixed horizontal front bar blades, w/o rear blades, and c/w Opposed Blade Damper.
- Registers called Return Air Linear Bar Register and coded as **RLR** are always equipped with with Opposed Blade Damper (provided as standard).

## Linear Bar Grilles Without Rear Blades Construction and Dimensional Details

### Model RLG SD

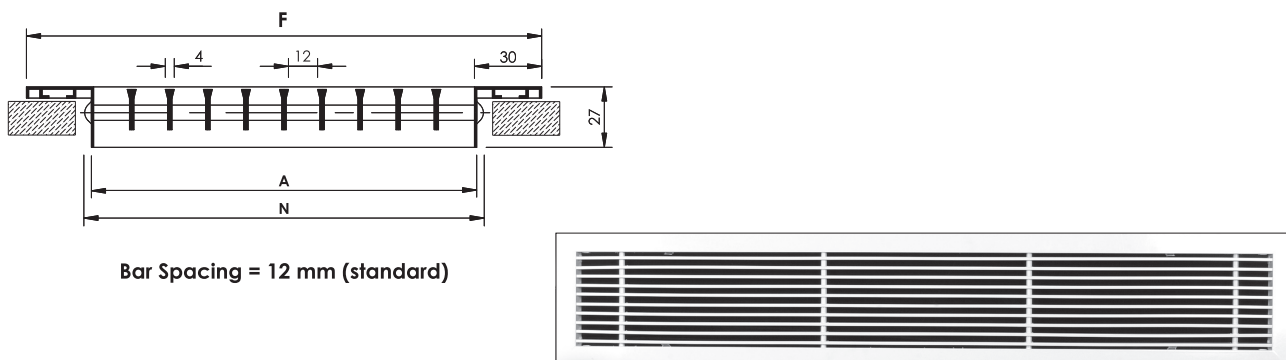

- **RLG** : is Return Air Linear Bar Grille, fixed horizontal front bar blades, w/o rear blades and Opposed Blade Damper.
- Grilles called Return Air Linear Bar Grille and coded as **RLG** are usually supplied w/o Opposed Blade Damper.

**N** : Nominal/Listed Size = Length (L) x Height (H)  
**A** : Actual Size = (L-10) x (H-10)  
**F** : Face Size = (L+50) x (H+50)

- Linear Bar Grilles / Registers furnished approximately 10 mm less than the Nominal/Listed Size.
- All dimensions are in mm and subject to  $\pm 1$  mm tolerance.

## Linear Bar Grilles and Registers Accessories

### A. Opposed Blade Damper

- Frame and Blades are of high quality Extruded Aluminium Profiles construction.
- Blades are designed to rotate opposite to each other.
- The specially designed blades have an overlapping lip which assures a tight closure.
- Generally, the opposed blade damper is attached to the linear bar grille and fixed to it by means of " S "clips.
- Blades are separated from it's frame by nylon bushes. This method of assembly provides maximum rattle - free performance and eliminates corrosion.
- Usually Damper standard surface finish is Aluminium in Mill Finish. Matt black powder coating color is also available on request (as an option).
- Screw type operation.

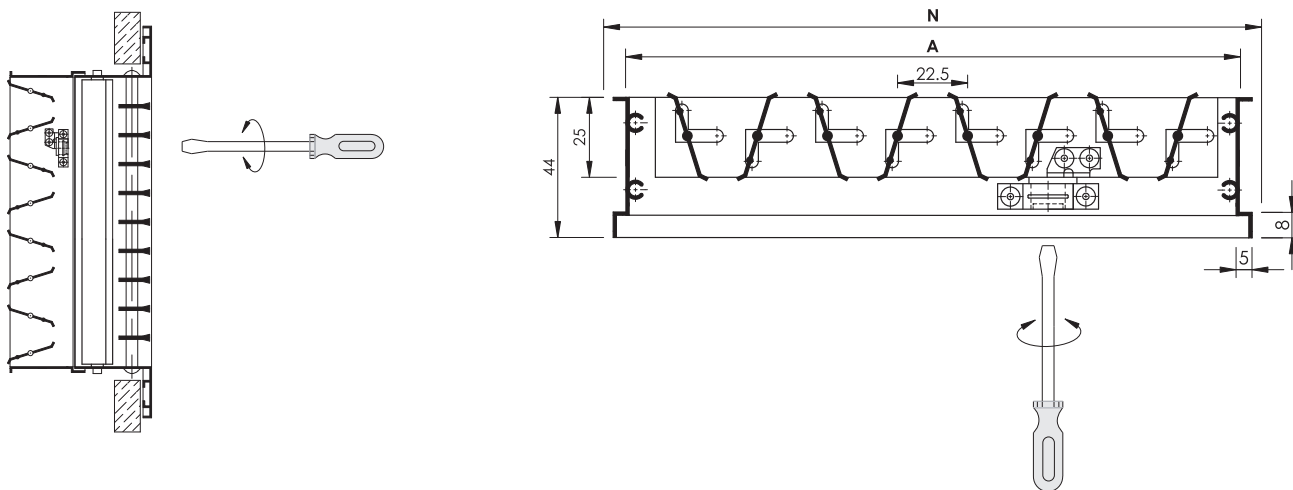

- The range from full open to full closed position of Damper blades can be easily adjusted by a screw driver accessible from the face of the linear bar register as shown in the figure.
- All dimensions are in mm and subject to  $\pm 1$  mm tolerance.

### B. Foam Type Rubber Gasket (Optional)

- Gasket type : Single Sided Self - Adhesive Foam.
- Gasket Function : Sealing.
- Gasket Benefits :
  - Stops Linear Bar Grille / Register rattling.
  - Minimize air infiltration.
  - Stops leaks and pressure losses.
  - Takes up unevenness of ceiling.
  - Easy to apply on site or in factory.
- To be applied around the perimeter of the back side of the Linear Bar Grille/Register to act as an air seal to prevent pressurised air from escaping from the sides of the outer frame when fixed to the wall.

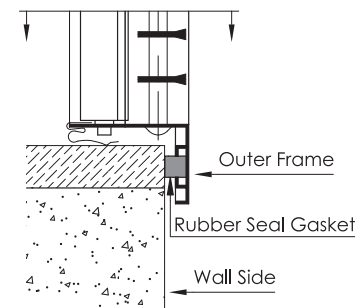

## Cross Sectional Drawings for Profiles used in Linear Bar Grilles / Registers

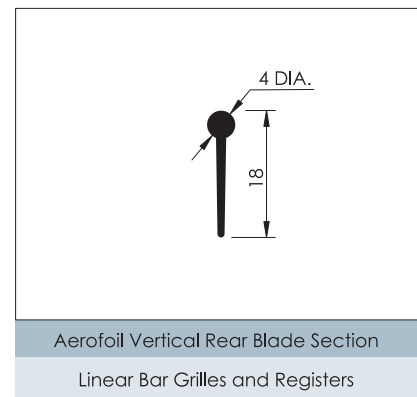
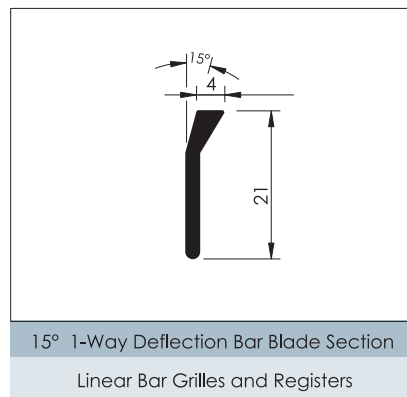
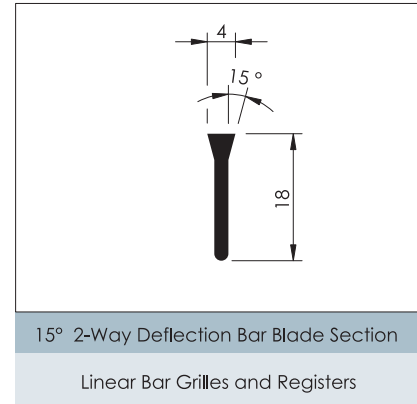
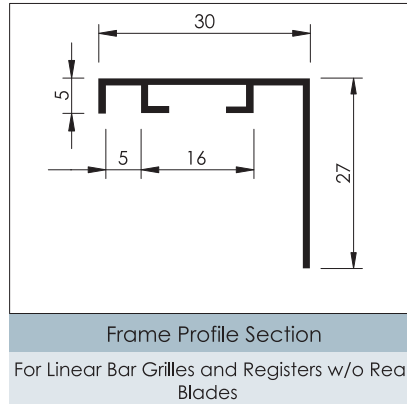
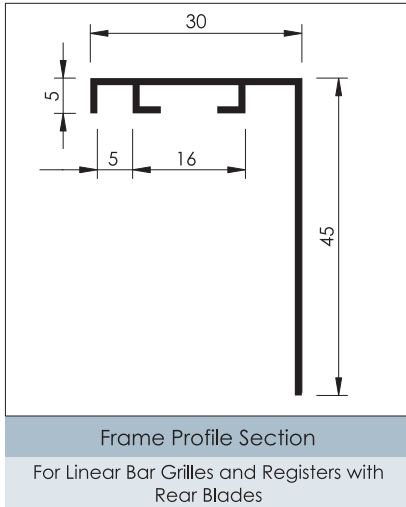

• All dimensions are in mm and subject to  $\pm 0.2$  mm tolerance.

## Available Fixing Mounting

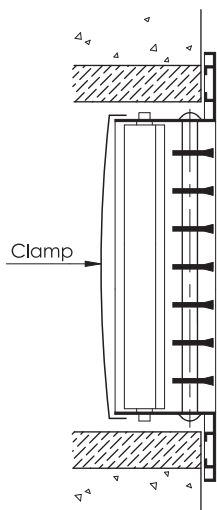

**A. Concealed Fixing (Clamp Mounting)**

• The Linear bar Grille / Register is fixed by means of aluminium clamp to the wall or ceiling where no screws are visible. Usually used when the Grille / Register is more than one meter in length.

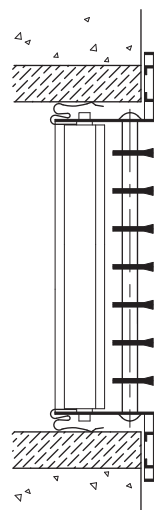

**B. Concealed Fixing (Spring Clip Mounting)**

• The Linear bar Grille / Register is fixed by means of spring clips to the wall where no screws are visible. Usually used when the Grille / Register is one meter or less in length.

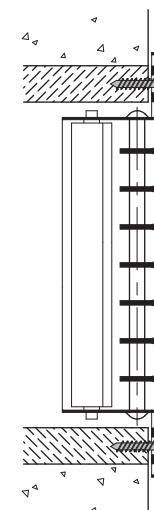

**C. Face Screw Fixing**

• The Linear bar Grille / Register is fixed to the wooden frame by means of visible screws. Can be used for any Grille / Register length.

## Engineering and Performance Data

TABLE LG - 07

EFFECTIVE AREA VALUES FOR LINEAR BAR GRILLES / REGISTERS WITH VERTICAL REAR BLADES MODEL SLR DD and SLG DD				
Height		Bar Spacing		
Inch	mm	@ 12 mm	@ 9 mm	@ 6 mm
2"	50	0.023	0.023	0.019
3"	75	0.038	0.034	0.030
4"	100	0.049	0.045	0.038
6"	150	0.076	0.068	0.057
8"	200	0.102	0.094	0.079
10"	250	0.128	0.117	0.098
12"	300	0.155	0.140	0.117
14"	350	0.185	0.170	0.143
16"	400	0.215	0.200	0.170
18"	450	0.246	0.230	0.196
20"	500	0.276	0.261	0.223
22"	550	0.306	0.291	0.249
24"	600	0.337	0.321	0.276

- Values are in m<sup>2</sup> and per one meter of running length.
- Damper at full open position.

TABLE LG - 08

EFFECTIVE AREA VALUES FOR LINEAR BAR GRILLES / REGISTERS W/O REAR BLADES MODEL RLR SD and RLG SD				
Height		Bar Spacing		
Inch	mm	@ 12 mm	@ 9 mm	@ 6 mm
2"	50	0.031	0.031	0.027
3"	75	0.051	0.047	0.043
4"	100	0.067	0.063	0.055
6"	150	0.103	0.095	0.084
8"	200	0.139	0.132	0.116
10"	250	0.176	0.164	0.145
12"	300	0.212	0.197	0.174
14"	350	0.252	0.237	0.210
16"	400	0.292	0.277	0.246
18"	450	0.332	0.317	0.282
20"	500	0.372	0.357	0.319
22"	550	0.412	0.397	0.355
24"	600	0.452	0.437	0.391

- Values are in m<sup>2</sup> and per one meter of running length.
- Damper at full open position.

## Engineering and Performance Data

TABLE LG - 09

L ▼	SELECTED EFFECTIVE AREA VALUES FOR MODEL SLR DD and SLG DD BAR SPACING = 12 mm					SELECTED EFFECTIVE AREA VALUES FOR MODEL RLR SD and RLG SD BAR SPACING = 12 mm					
	H ▶	100	150	200	250	300	100	150	200	250	300
500		0.024	0.037	0.049	0.062	0.075	0.032	0.050	0.068	0.085	0.103
550		0.026	0.040	0.054	0.068	0.083	0.036	0.055	0.075	0.094	0.114
600		0.029	0.045	0.060	0.076	0.091	0.039	0.061	0.082	0.104	0.125
650		0.031	0.048	0.065	0.082	0.099	0.043	0.066	0.089	0.113	0.136
700		0.034	0.053	0.071	0.089	0.108	0.046	0.072	0.097	0.122	0.147
750		0.037	0.056	0.076	0.096	0.115	0.050	0.077	0.104	0.131	0.158
800		0.039	0.061	0.082	0.103	0.124	0.053	0.082	0.111	0.140	0.169
850		0.041	0.063	0.085	0.108	0.130	0.056	0.087	0.117	0.148	0.178
900		0.044	0.068	0.091	0.115	0.139	0.060	0.092	0.125	0.157	0.190
950		0.046	0.071	0.096	0.121	0.146	0.063	0.098	0.132	0.166	0.201
1000		0.049	0.076	0.102	0.128	0.155	0.067	0.103	0.139	0.176	0.212
1050		0.052	0.079	0.107	0.135	0.163	0.070	0.108	0.147	0.185	0.223
1100		0.054	0.084	0.113	0.142	0.171	0.074	0.114	0.154	0.194	0.234
1150		0.057	0.087	0.118	0.148	0.179	0.077	0.119	0.161	0.203	0.245
1200		0.059	0.091	0.122	0.154	0.186	0.080	0.124	0.167	0.211	0.254
1250		0.061	0.094	0.127	0.160	0.193	0.084	0.129	0.174	0.220	0.265
1300		0.064	0.099	0.133	0.168	0.202	0.087	0.134	0.182	0.229	0.276
1350		0.067	0.102	0.138	0.174	0.210	0.091	0.140	0.189	0.238	0.287
1400		0.069	0.107	0.144	0.181	0.219	0.094	0.145	0.196	0.247	0.299
1450		0.072	0.110	0.149	0.188	0.226	0.098	0.151	0.204	0.257	0.310
1500		0.075	0.115	0.155	0.195	0.235	0.101	0.156	0.211	0.266	0.321
1550		0.077	0.118	0.160	0.201	0.243	0.105	0.161	0.218	0.275	0.332
1600		0.080	0.123	0.166	0.208	0.251	0.108	0.167	0.226	0.284	0.343
1650		0.082	0.126	0.171	0.215	0.259	0.112	0.172	0.233	0.293	0.354
1700		0.085	0.131	0.176	0.222	0.268	0.115	0.178	0.240	0.303	0.365
1750		0.087	0.134	0.181	0.228	0.275	0.119	0.183	0.247	0.312	0.376
1800		0.090	0.139	0.187	0.236	0.284	0.122	0.188	0.255	0.321	0.387
1850		0.093	0.142	0.192	0.242	0.292	0.126	0.194	0.262	0.330	0.398
1900		0.095	0.147	0.198	0.249	0.301	0.129	0.199	0.269	0.339	0.410
1950		0.098	0.150	0.203	0.256	0.308	0.133	0.205	0.277	0.349	0.421
2000		0.101	0.155	0.209	0.263	0.317	0.136	0.210	0.284	0.358	0.432
2050		0.103	0.158	0.214	0.269	0.325	0.140	0.215	0.291	0.367	0.443
2100		0.106	0.163	0.220	0.276	0.333	0.143	0.221	0.299	0.376	0.454
2150		0.108	0.166	0.225	0.283	0.341	0.147	0.226	0.306	0.385	0.465
2200		0.111	0.171	0.230	0.290	0.350	0.150	0.232	0.313	0.395	0.476
2250		0.113	0.174	0.235	0.296	0.357	0.154	0.237	0.320	0.404	0.487
2300		0.116	0.179	0.241	0.304	0.366	0.157	0.242	0.328	0.413	0.498
2350		0.129	0.182	0.246	0.310	0.374	0.161	0.248	0.335	0.422	0.509
2400		0.121	0.187	0.252	0.317	0.383	0.164	0.253	0.342	0.431	0.521
2450		0.124	0.190	0.257	0.324	0.390	0.168	0.259	0.350	0.441	0.532
2500		0.127	0.195	0.263	0.331	0.399	0.171	0.264	0.357	0.450	0.543

- L & H dimensions are in mm, Areas in m<sup>2</sup>.
- Damper at full open position.

## Engineering and Performance Data General Selection Diagram

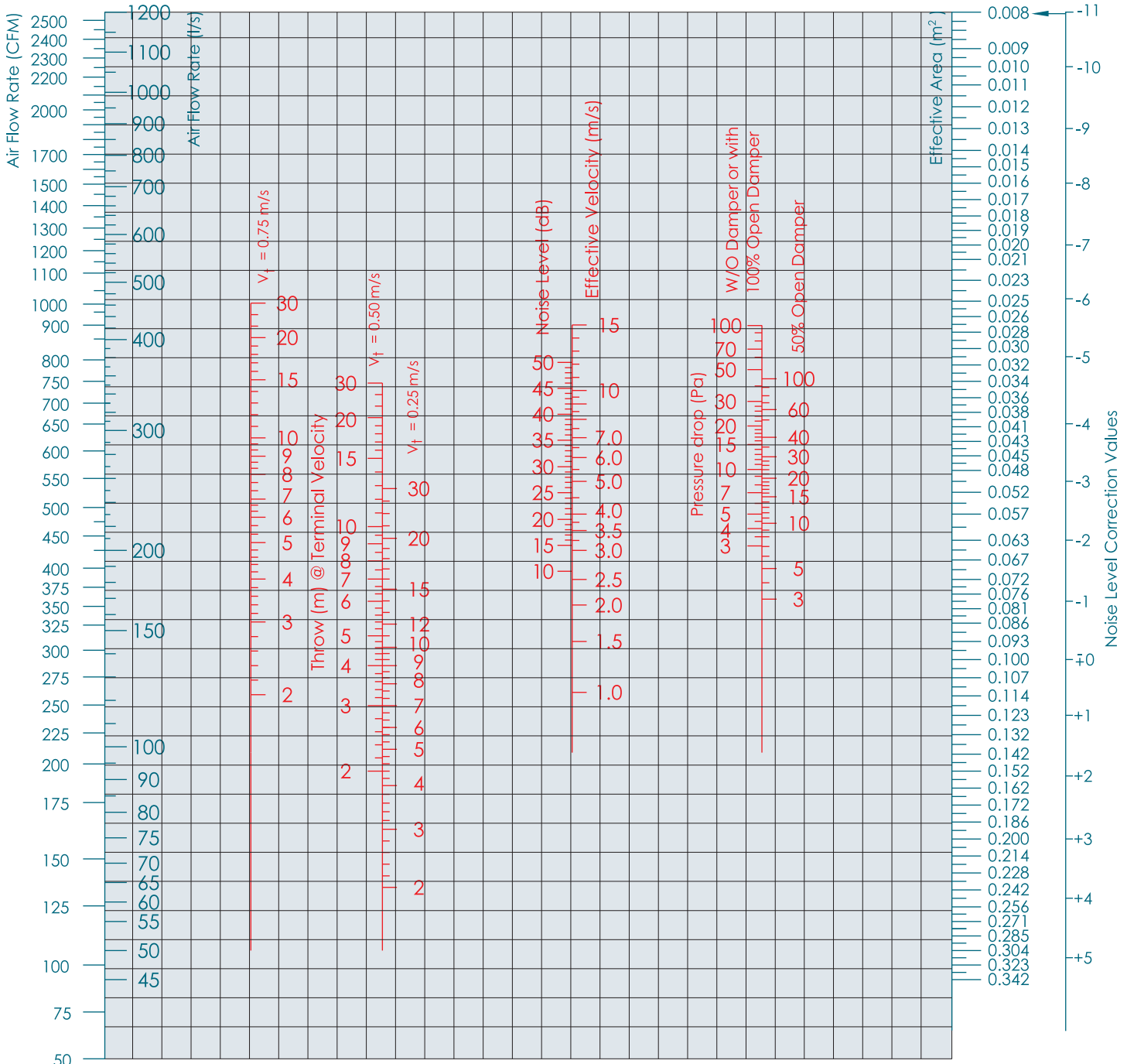

- Always draw a straight horizontal line from Effective Area point in direction to Noise Level correction line on right side to obtain its correction value.

### Correction Multipliers / Values :

Blades Deflection	22 1/2 °	45 °
Velocity	x 1.20	x 1.40
Pressure Drop	x 1.30	x 1.60
Throw	x 0.80	x 0.60
Noise Level	+ 2.0	+ 3.0



## How to use this Diagram ?

**Case I :** Size and Air Flow Rate are given

**Illustrative Example :**

Given Data : Required Model : SLR DD  
 Bar Spacing : 12 mm  
 Nominal Size : 1500 x 200 mm  
 Air Flow Rate : 750 CFM

Assume Damper at full open position.  
 See Page No. LG - 10 Table No. LG - 09, Effective Area = 0.155 m<sup>2</sup>,

Apply the CFM and Effective Area values to the diagram and draw a straight line connecting both of them, easily from the intersection you can read all the related data as below :-

- V<sub>eff.</sub> = 2.6 m/s (intersection point of drawn line with V<sub>eff.</sub> vertical line).
- Noise Level < 15 dB (the Value where the drawn line intersecting the Noise Level Vertical line after checking Noise Level correction values).
- Pressure Drop < 3 Pa (from the same V<sub>eff.</sub> point draw a horizontal line intersecting the opposite Pressure Drop vertical line and read this value).
- Throw @ V<sub>t</sub> = 0.25 m/s > 30 m (Intersection point of drawn line with Throw vertical line @ V<sub>t</sub> = 0.25 m/s).
- @ V<sub>t</sub> = 0.50 m/s = 14.0 m (Intersection point of drawn line with Throw vertical line @ V<sub>t</sub> = 0.50 m/s).
- @ V<sub>t</sub> = 0.75 m/s = 8.0 m (where the drawn line intersecting the Throw vertical line @ V<sub>t</sub> = 0.25 and 0.50 m/s draw a horizontal straight line toward the opposite Throw vertical line @ V<sub>t</sub> = 0.75 m/s and read this value).

Case I : Size and Air Flow Rate are given

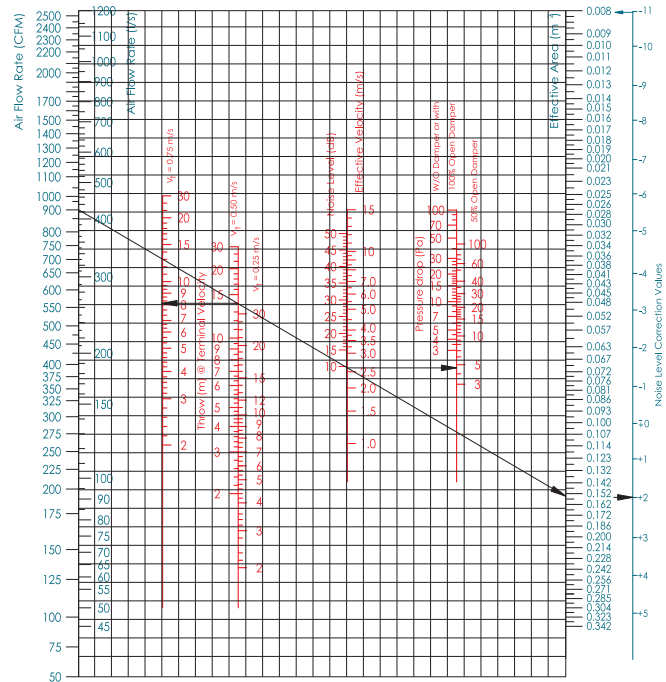

Case II : Air Flow Rate and Noise Level are given

**Case II :** Air Flow Rate and Noise Level are given

**Illustrative Example :**

Given Data : Required Model : RLG SD  
 Bar Spacing : 6 mm  
 Air Flow Rate : 600 CFM  
 Noise Level : not to exceed 30 dB

Assume V<sub>eff.</sub> = 3.0 m/s to find that Noise Level = (14 - 0) = 14 (Not exceeding 30 dB), then other related data can be read as below :-

- Effective Area = 0.09 m<sup>2</sup>.
- See page No. LG - 09 table No. LG - 08, (@ Bar Spacing = 6 mm) if you choose 4 " grille height, the Effective Area for the same = 0.055 m<sup>2</sup> per one meter length, so the required grille length will be 0.09/0.055 = 1.64 m.
- Grilles Nominal Size = 1640 x 100 mm.
- Pressure Drop = 3.0 Pa.
- Throw Values : not required for Return Air Grilles.

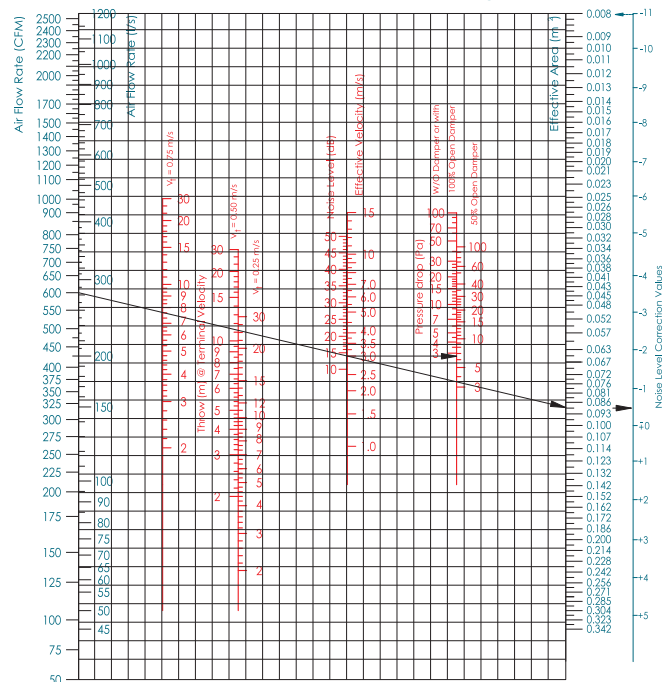



## Ordering Data

### • Available Surface Finishes For Linear Bar Grilles and Registers :

- Natural / Matt Silver Anodized .
- Powder Coating ( Standard Colors are white RAL 9010 / 9016, other optional colors if required to be provided in RAL - No. only and charged extra).
- Aluminium in Mill Finish.
- Other Special Finishes ( on request if available ).

### • Available Surface Finishes For Opposed Blade Dampers :

- Aluminium in Mill Finish (standard).
- Matt Black Powder Coating (optional).

### • Ordering Specifications :

#### Specify :

- 1 . Linear Bar Grille / Register Description (Supply, Return, Extract, Dummy, ..... etc.).
- 2 . Fixed Front Bar blades with or w/o vertical rear blades.
- 3 . Opposed Blade Damper Surface Finish (only mention if required in black color).
- 4 . Linear Bar Grille / Register Height.
- 5 . Linear Bar Grille / Register Length.
- 6 . Quantity.
- 7 . Linear Bar Grille / Register Surface Finish.
- 8 . RAL - No.(only mention if powder coating surface finish is required).
- 9 . Type of Fixing ( see page No. LG - 08).
- 10 . Optional Accessories ( Gasket, or others).
- 11 . Fabrication Notes : only mention if any the following is required :
  - 15° - one way deflection.
  - Non-standard spacing, 6 or 9 mm.
  - Curved shaped.

#### Example 1 :

1	2	3	4	5	6	7	8	9	10	11
SLR	DD	BD	H = 6" or 150 mm	1200 mm	62	Powder Coating	9016	Clamp	-	-

#### Example 2 :

1	2	3	4	5	6	7	8	9	10	11
SLG	DD	-	H = 8" or 200 mm	60"	120	Silver Anodized	-	Spring Clip	With Rubber Gasket	15° one way

#### Example 3 :

1	2	3	4	5	6	7	8	9	10	11
RLG	SD	-	H = 12" or 300 mm	2130 mm	3	Powder Coating	1013 (Optional)	Screw	-	Curve

# LINEAR BAR GRILLES AND REGISTERS



A large table area consisting of 25 horizontal dotted lines, intended for technical specifications or data entry.